



Hardware User Guide

Q-SYS Core 110f

Q-SYS Cinema Core 110c

TD-001541-01-B



EXPLANATION OF TERMS AND SYMBOLS

The term "WARNING!" indicates instructions regarding personal safety. If the instructions are not followed the result may be bodily injury or death.

The term "CAUTION!" indicates instructions regarding possible damage to physical equipment. If these instructions are not followed, it may result in damage to the equipment that may not be covered under the warranty.

The term "IMPORTANT!" indicates instructions or information that are vital to the successful completion of the procedure.

The term "NOTE" is used to indicate additional useful information.



The intent of the lightning flash with arrowhead symbol in a triangle is to alert the user to the presence of un-insulated "dangerous" voltage within the product's enclosure that may be of sufficient magnitude to constitute a risk of electric shock to humans.



The intent of the exclamation point within an equilateral triangle is to alert the user to the presence of important safety, and operating and maintenance instructions in this manual.



IMPORTANT SAFETY INSTRUCTIONS



WARNING!: TO PREVENT FIRE OR ELECTRIC SHOCK, DO NOT EXPOSE THIS EQUIPMENT TO RAIN OR MOISTURE.

Elevated Operating Ambient - If installed in a closed or multi-unit rack assembly, the ambient operating temperature of the rack environment may be greater than room ambient. Consideration should be given to ensure that the maximum operating temperature range (0°C to 50°C (32°F to 122°F) is not exceeded. Reduced Air Flow – Installation of the equipment in a rack should be such that the amount of air flow required for safe operation of the equipment is not compromised.

1. Read these instructions.
2. Keep these instructions.
3. Heed all warnings.
4. Follow all instructions.
5. Do not use this apparatus near water.
6. Do not submerge the apparatus in water or liquids.
7. Do not use any aerosol spray, cleaner, disinfectant or fumigant on, near or into the apparatus.
8. Clean only with a dry cloth.
9. Do not block any ventilation opening. Install in accordance with the manufacturer's instructions.
10. Keep all ventilation openings free of dust or other matter.
11. Do not install near any heat sources such as radiators, heat registers, stoves, or other apparatus (including amplifiers) that produce heat.
12. To reduce the risk of electrical shock, the power cord shall be connected to a mains socket outlet with a protective earthing connection.
13. Do not defeat the safety purpose of the polarized or grounding-type plug. A polarized plug has two blades with one wider than the other. A grounding type plug has two blades and a third grounding prong. The wide blade or the third prong are provided for your safety. If the provided plug does not fit into your outlet, consult an electrician for replacement of the obsolete outlet.
14. Protect the power cord from being walked on or pinched particularly at plugs, convenience receptacles, and the point where they exit from the apparatus.
15. Do not unplug the unit by pulling on the cord, use the plug.
16. Only use attachments/accessories specified by the manufacturer.
17. Unplug this apparatus during lightning storms or when unused for long periods of time.
18. Refer all servicing to qualified service personnel. Servicing is required when the apparatus has been damaged in any way, such as power-supply cord or plug is damaged, liquid has been spilled or objects have fallen into the apparatus, the apparatus has been exposed to rain or moisture, does not operate normally, or has been dropped.
19. The appliance coupler, or the AC Mains plug, is the AC mains disconnect device and shall remain readily accessible after installation.
20. Adhere to all applicable, local codes.
21. Consult a licensed, professional engineer when any doubt or questions arise regarding a physical equipment installation.

Maintenance and Repair



WARNING!: Advanced technology, e.g., the use of modern materials and powerful electronics, requires specially adapted maintenance and repair methods. To avoid a danger of subsequent damage to the apparatus, injuries to persons and/or the creation of additional safety hazards, all maintenance or repair work on the apparatus should be performed only by a QSC authorized service station or an authorized QSC International Distributor. QSC is not responsible for any injury, harm or related damages arising from any failure of the customer, owner or user of the apparatus to facilitate those repairs.

LITHIUM BATTERY WARNING



WARNING!: THIS EQUIPMENT CONTAINS A NON-RECHARGEABLE LITHIUM BATTERY. LITHIUM IS A CHEMICAL KNOWN TO THE STATE OF CALIFORNIA TO CAUSE CANCER OR BIRTH DEFECTS. THE NON-RECHARGEABLE LITHIUM BATTERY CONTAINED IN THIS EQUIPMENT MAY EXPLODE IF IT IS EXPOSED TO FIRE OR EXTREME HEAT. DO NOT SHORT CIRCUIT THE BATTERY. DO NOT ATTEMPT TO RECHARGE THE NON-RECHARGEABLE LITHIUM BATTERY. THERE IS A RISK OF EXPLOSION IF THE BATTERY IS REPLACED BY AN INCORRECT TYPE.

FCC Statement



NOTE: This equipment has been tested and found to comply with the limits for a Class B digital device, pursuant to Part 15 of the FCC Rules.

These limits are designed to provide reasonable protection against harmful interference in a residential installation. This equipment generates, uses and can radiate radio frequency energy and, if not installed and used in accordance with the instructions, may cause harmful interference to radio communications. However, there is no guarantee that interference will not occur in a particular installation. If this equipment does cause harmful interference to radio or television reception, which can be determined by turning the equipment off and on, the user is encouraged to try to correct the interference by one or more of the following measures:

- Reorient or relocate the receiving antenna.
- Increase the separation between the equipment and receiver.
- Connect the equipment into an outlet on a circuit different from that to which the receiver is connected.
- Consult the dealer or an experienced radio/TV technician for help.

FCC Part 68 / ACTA

This equipment complies with Part 68 of the FCC rules and the requirements adopted by the ACTA. On the rear panel of this equipment is a label that contains, among other information, a product identifier in the format US:AAAEQ##TXXXX. If requested, this number must be provided to the telephone company.

A plug and jack used to connect this equipment to the premises wiring and telephone network must comply with the applicable FCC Part 68 rules and requirements adopted by the ACTA. A compliant telephone cord and modular plug is provided with this product. It is designed to be connected to a compatible modular jack that is also compliant. See installation instructions for details.

The REN is used to determine the number of devices that may be connected to a telephone line. Excessive RENs on a telephone line may result in the devices not ringing in response to an incoming call. In most but not all areas, the sum of RENs should not exceed five (5.0). To be certain of the number of devices that may be connected to a line, as determined by the total RENs, contact the local telephone company. The REN for this product is part of the product identifier that has the format US:AAAEQ##TXXXX. The digits represented by ## are the REN without a decimal point (e.g., 03 is a REN of 0.3).

If this equipment, US:6M2BR00BCORE110F, causes harm to the telephone network, the telephone company will notify you in advance that temporary discontinuance of service may be required. But if advance notice isn't practical, the telephone company will notify the customer as soon as possible. Also, you will be advised of your right to file a complaint with the FCC if you believe it is necessary.

The telephone company may make changes in its facilities, equipment, operations or procedures that could affect the operation of the equipment. If this happens the telephone company will provide advance notice in order for you to make necessary modifications to maintain uninterrupted service. If trouble is experienced with this equipment US:6M2BR00BCORE110F, for repair or warranty information, please contact QSC, LLC 1675 MacArthur Boulevard, Costa Mesa, CA 92626-1468 U.S. 714.754.6175. If the equipment is causing harm to the telephone network, the telephone company may request that you disconnect the equipment until the problem is resolved.

Connection to party line service is subject to state tariffs. Contact the state public utility commission, public service commission or corporation commission for information.

Electrical Safety Advisory:

Parties responsible for equipment requiring AC power should consider including an advisory notice in their customer information suggesting the customer use a surge arrester. Telephone companies report that electrical surges, typically lightning transients, are very destructive to customer terminal equipment connected to AC power sources. This has been identified as a major nationwide problem.

Industry Canada

This product meets the applicable Industry Canada technical specifications.

The Ringer Equivalence Number (REN=0.1) indicates the maximum number of devices allowed to be connected to a telephone interface. The termination of an interface may consist of any combination of devices subject only to the requirement that the sum of the RENs of all the devices not exceed five. / L'indice d'équivalence de la sonnerie (IES=0.1) sert à indiquer le nombre maximal de terminaux qui peuvent être raccordés à une interface téléphonique. La terminaison d'une interface peut consister en une combinaison quelconque de dispositifs, à la seule condition que la somme d'indices d'équivalence de la sonnerie de tous les dispositifs n'excède pas cinq.



IMPORTANT!: The product is not intended to be installed as a system for providing emergency voice communication or to be installed in areas specified by ANSI/NFPA 72, "National Fire Alarm Code."

RoHS STATEMENT

The QSC Q-SYS Core 110 Series is in compliance with European Directive 2011/65/EU – Restriction of Hazardous Substances (RoHS2).

The QSC Q-SYS Core 110 Series is in compliance with "China RoHS" directives. The following chart is provided for product use in China and its territories:

QSC Q-SYS Core 110 Series						
部件名称 (Part Name)	有害物质 (Hazardous Substances)					
	铅 (Pb)	汞 (Hg)	镉 (Cd)	六价铬 (Cr(vi))	多溴联苯 (PBB)	多溴二苯醚 (PBDE)
电路板组件 (PCB Assemblies)	X	O	O	O	O	O
机壳装配件 (Chassis Assemblies)	X	O	O	O	O	O

本表格依据 SJ/T 11364 的规定编制。

O: 表示该有害物质在该部件所有均质材料中的含量均在 GB/T 26572 规定的限量要求以下。

X: 表示该有害物质至少在该部件的某一均质材料中的含量超出 GB/T 26572 规定的限量要求。(目前由于技术或经济的原因暂时无法实现替代或减量化。)

This table is prepared following the requirement of SJ/T 11364.

O: Indicates that the concentration of the substance in all homogeneous materials of the part is below the relevant threshold specified in GB/T 26572.



X: Indicates that the concentration of the substance in at least one of all homogeneous materials of the part is above the relevant threshold specified in GB/T 26572.

(Replacement and reduction of content cannot be achieved currently because of the technical or economic reason.)

Warranty

For a copy of the QSC Limited Warranty, visit the QSC website at www.qsc.com

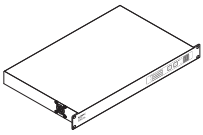
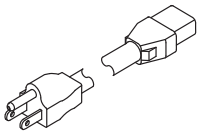
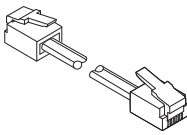
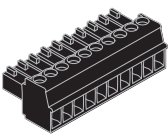
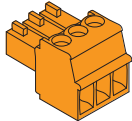
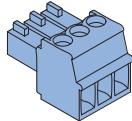
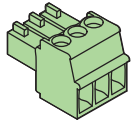
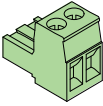
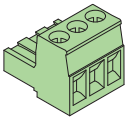
Package Contents

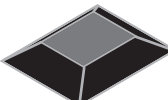
 Core 110	1	 AC Power cord	1	 Phone cord	1	 GPIO (black)	4
 Mic/Line In (orange)	8	 Flex Channels (blue)	8	 Mic/Line Out (green)	8	 External Power (green)	1
 RS232 Tx/Rx (green)	1	 Core 110 Installation TD-001541	1	 QSC Warranty TD-000453	1	 Rubber feet	4

Installation

The following steps are written in the recommended installation order.

Rack-Mounting



CAUTION! Be sure that each side has a minimum of 2 cm clearance. Make sure that there is a fresh-air supply on the left side of the unit.

The Core 110 is designed to be mounted in a standard rack-mount unit. The Core is 1RU high, and 283mm (11.1 in) deep.

- Secure the Core in the rack with four screws in front (screws not included).

Features

Front Panel

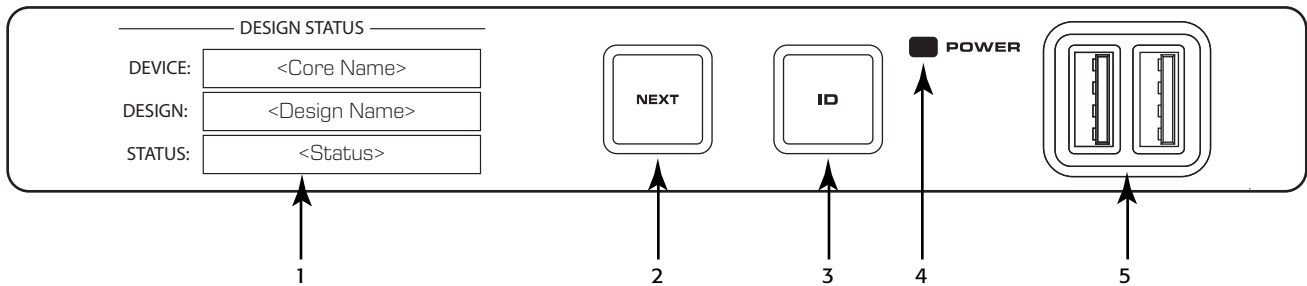

— Figure 1 —

- | | |
|---|---|
| <ol style="list-style-type: none"> OLED Display – displays information about the core's settings and status. Next button – cycles through the information pages | <ol style="list-style-type: none"> ID button – locates the Core in Q-SYS Designer GUI and Configurator Power LED – illuminates blue when the Core is on USB Type A Host connectors (2) |
|---|---|

Rear Panel (left side)

All audio inputs and outputs use one 3-position, 3.5mm Euro connector for each channel. GPIO uses one 10-position 3.5mm Euro connector for each row.

All inputs and outputs are configured in Q-SYS Designer.

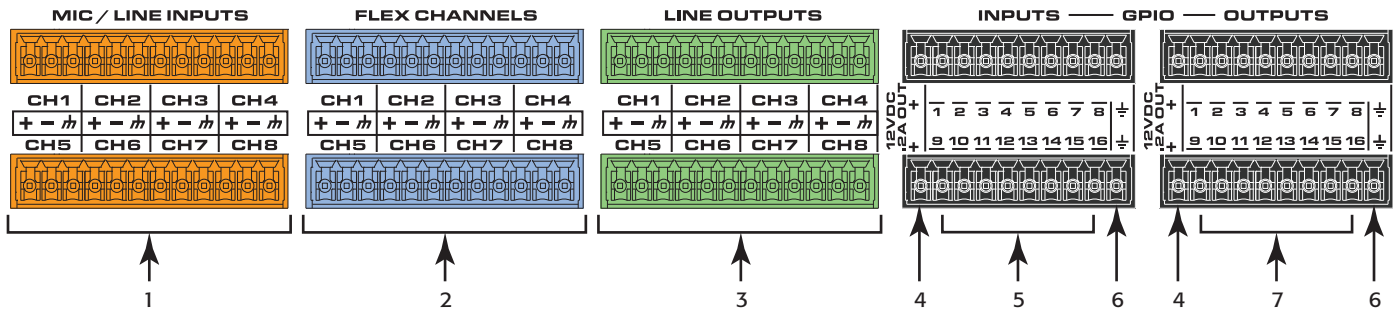

— Figure 2 —

1. Mic/Line Inputs – eight channels, balanced or unbalanced, phantom power – orange
2. Flex Channels – eight user-configurable input/output channels, balanced or unbalanced, phantom power on inputs – blue
3. Mic/Line Outputs – eight channels, balanced or unbalanced - green
4. 12VDC, 0.2A Outputs + uses connector pins 1 and 11 (not numbered)
5. General-purpose Inputs – 16 inputs, 0-24V analog input, or contact closure (Pins labeled 1–16 equal pins 1–16 in the Q-SYS Designer GPIO Input component)
6. Earth ground – uses pins 10 and 20 (not numbered)
7. General-purpose Outputs – 16 outputs, open collector (24V, 0.2A maximum) with pull up to +3.3V (Pins labeled 1–16 equal pins 1–16 in the Q-SYS Designer GPIO Output component)

The following connections use the black Euro plug.

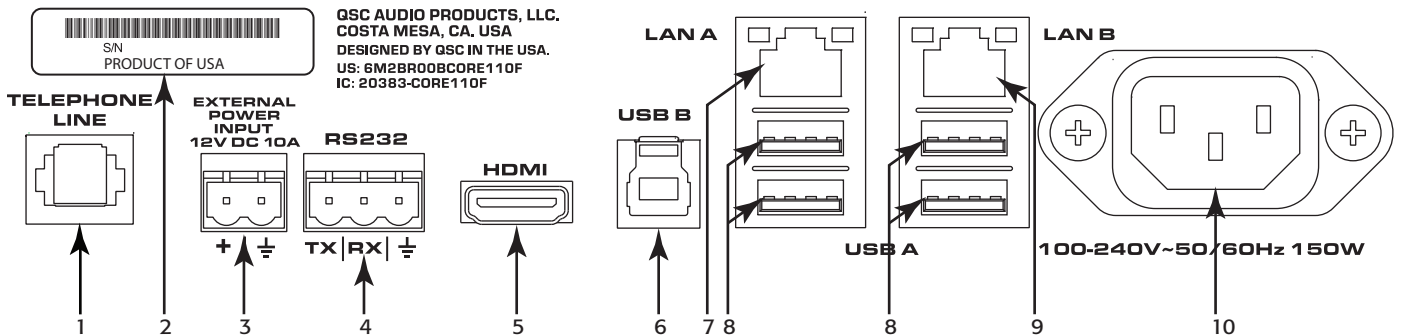

— Figure 3 —

1. Telephone Line – RJ11 (6P2C)
2. Serial Number of the Core 110
3. External Power Input – Auxiliary power, 12VDC, 10A, 2-pin, 5 mm Euro connector.
4. RS232 – Transmit and receive, 3-pin, 5 mm, Euro connector
5. HDMI – for future use
6. USB Type B Device connector
7. LAN A – Q-LAN, control, VoIP, WAN streaming, AES67 etc., RJ45
8. USB Type A Host connectors (4) for future use
9. LAN-B – Redundancy, control, VoIP, etc.
10. A/C Power Input – IEC connector, 100-240V ~ 50-60 Hz, 150W, universal power supply

Connections

Input / Output Connectors

Figure 4 – Figure 7

3-Pin, color-coded, Euro Connectors

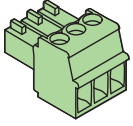

- Mic/Line Inputs (8 orange)
- Flex Channels (8 blue)
- Mic/Line Outputs (8 green)



CAUTION!: A single channel consists of three pins. It is possible to plug in a connector that straddles two channels. Be sure that the plugs do not straddle two channels.

Balanced

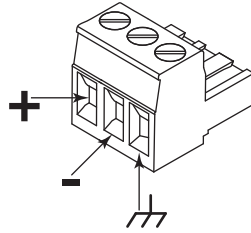

— Figure 4 —

Unbalanced

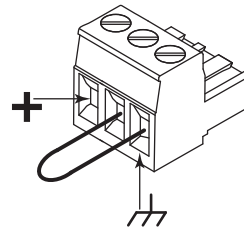

— Figure 5 —

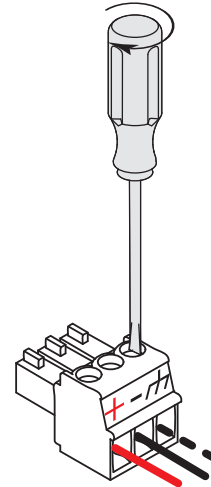

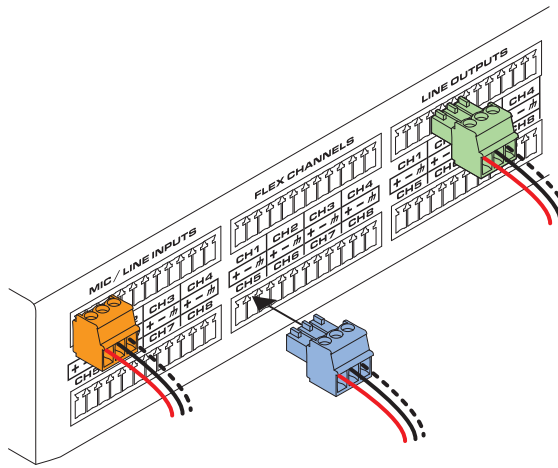

— Figure 6 —



— Figure 7 —

Communication and Power Connectors

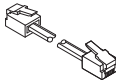
Make the following connections as required. Refer to Figure 5

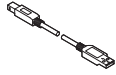
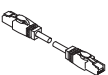
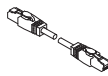
1.  Telephone Cable, RJ12,6-Conductor
2.  2-pin Euro connector – for +12VDC 10A
3.  3-pin Euro connector – for RS232 TX and RX
4.  USB Type B – for external devices, not supplied
5.  RJ45/Cat5E – audio, & control, not supplied
6.  RJ45/CAT5E – audio, & control, redundant network, not supplied

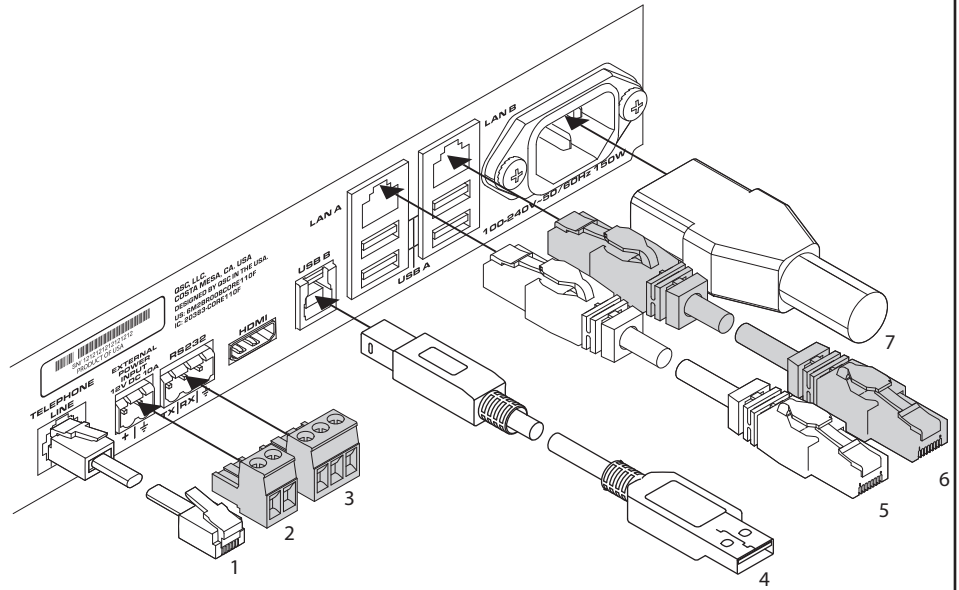

— Figure 8 —

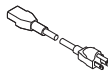

WARNING!: The AC Mains plug, is the AC mains disconnect device and shall remain readily accessible after installation.

7.  AC Mains – The Core 110 has a Universal power supply 100 – 240 VAC, 50 – 60 Hz, with an IEC connector.

Front Panel OLED Screens

Design Status

Refer to Figure 9

- Device – The name of the Core as defined in Q-SYS Designer.
- Design – The name of the currently running design.
- Status –
 - OK – Audio is good, hardware is good.
 - Compromised – Audio is good but a redundancy mechanism is active (one LAN down but the other is still up) or a non-fatal hardware problem exists (fans too slow, temperature higher than expected, etc.)
 - Fault – Audio is not passing, or hardware is malfunctioning or mis-configured
 - Missing – A piece of hardware, defined in the design, has not been discovered. Audio is not passing through that piece of hardware.
 - Initializing – Starting the firmware, configuration update, and the design. Audio is obviously bad.
 - Not Present – A virtual component in the design, that is designated as Dynamically Paired, and Not Required, has no hardware assigned to it.

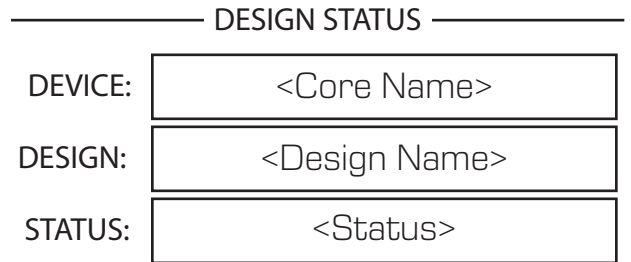

— Figure 9 —

System Status

Refer to Figure 10

- Firmware – A three-section number identifying the major release, minor release, and maintenance release. For example, 5.0.06.
- Temp – The current chassis temperature of the Core.
 - Compromised threshold = 60° C
 - Fault threshold = 70° C
- Fan Speed – This number varies with the temperature.

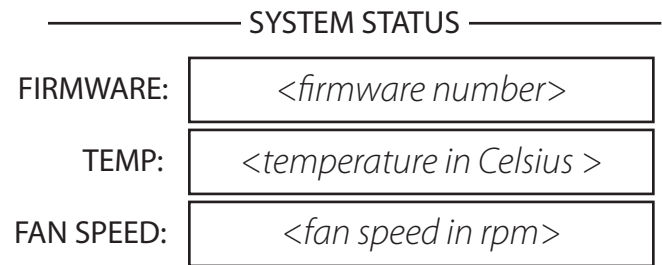

— Figure 10 —

LAN A

Refer to Figure 11

You can edit this information in the Q-SYS Configurator.

- Static or Auto – Displays next to LAN A, indicates if the Core's IP Address is Static or Automatic.
- IP Address – The IP Address assigned to the Core's LAN A. LAN A is the primary Q-LAN connection to the Core, and is required.
- Net Mask – The Net Mask assigned to the Core.
- Gateway – The Gateway assigned to the Core.

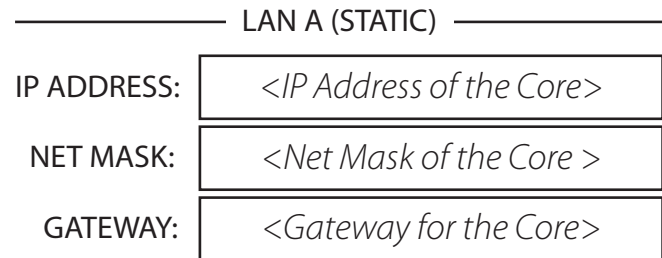

— Figure 11 —

LAN B

LAN B is used for redundancy, and is not required. The information is the same as LAN A.

Input / Flex In Channels Status

Refer to Figure 12 (Flex Input screen shown)



NOTE: If a Flex channel is set to Input, there is no information shown under the same channel on the Flex Out screen. If the Flex channel is set to output, there is no information for that channel on the Flex In screen. Compare Figure 12 and Figure 13.

The Input and Flex Input screens show the Mute, Clip, Signal, and +48V (phantom power) for the eight Mic/Line input channels.

- Mute – Displays a "muted loudspeaker" when the channel is muted.
- Clip – Displays a solid circle under the channel having an input signal that is overdriving the associated channel input.
- Signal – Displays a solid circle when there is a signal present on the associated channel.
- +48V – Displays a solid circle when the phantom power is turned on for the associated channel.

Flex In	1	2	3	4	5	6	7	8
Mute								
Clip	●	○	○				○	○
Signal	●	○	○				○	○
+48V	○	●	○				○	○

— Figure 12 —

Output / Flex Out Channels Status

Refer to Figure 13 (Flex Output screen shown)

The Output and Flex Output screens show the Mute, Clip, and Signal, for the eight Mic/Line output channels.

- Mute – Displays a "muted loudspeaker" when the channel is muted.
- Clip – Displays a solid circle under the channel having an output signal over driving the associated channel output.
- Signal – Displays a solid circle when there is a signal present on the associated channel.

Flex Out	1	2	3	4	5	6	7	8
Mute								
Clip				○	○	○		
Signal				●	●	○		

— Figure 13 —

Dimensions

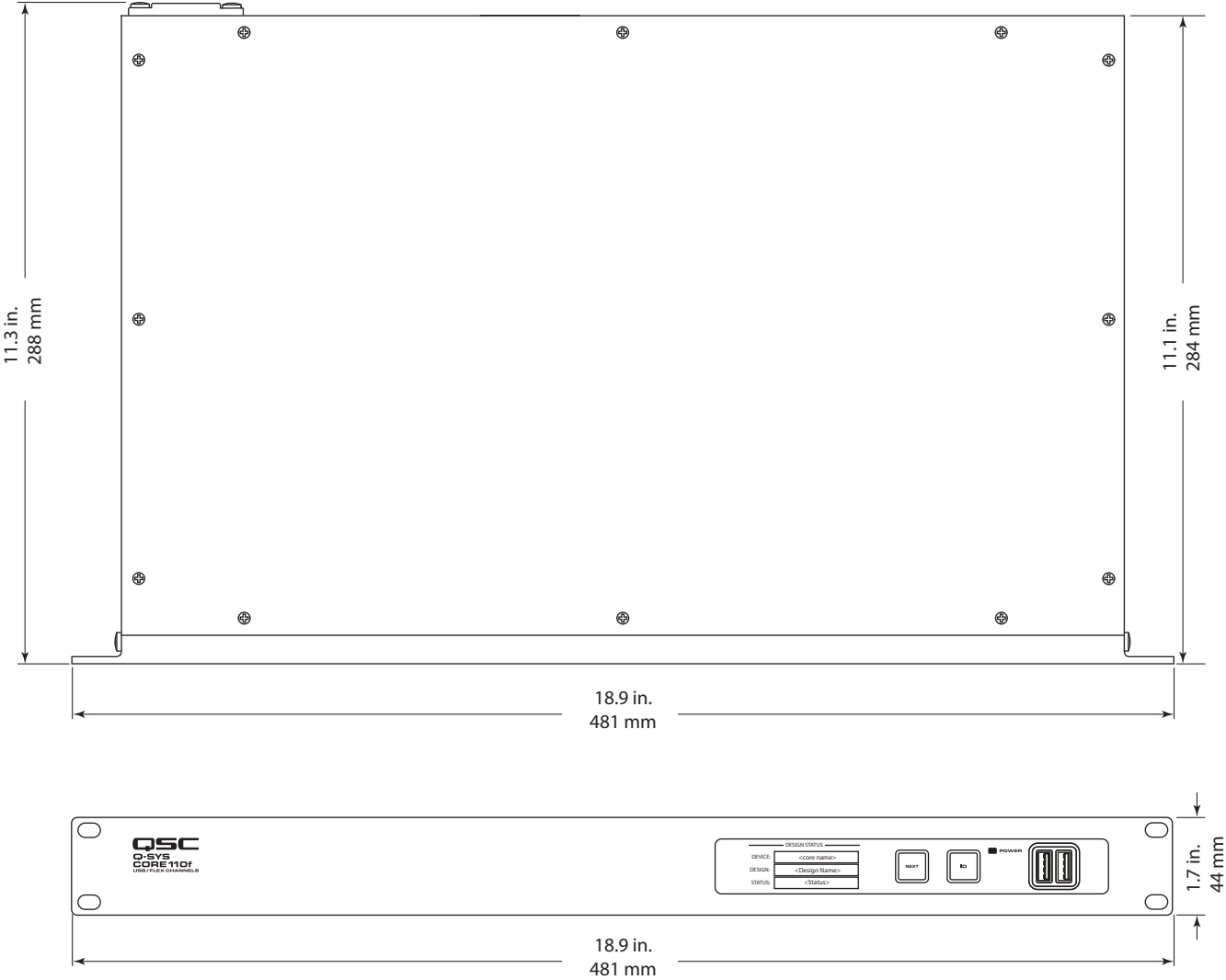

— Figure 14 —

Q-SYS Core 110 Series Specifications

Specification	Value
Input Frequency Response	
20 Hz to 20 kHz @ +21 dBu	+0.05 dB/-0.5 dB
Input THD+N @ 1 kHz	
@ +21 dBu Sensitivity and @ +21 dBu input	< 0.1%
@ +21 dBu Sensitivity and @ +10 dBu input	< 0.0015%
@ +10 dBu Sensitivity and @ +8 dBu input	< 0.001%
@ -10 dBu Sensitivity and @ -10.5 dBu input	< 0.001%
@ -39 dBu Sensitivity and @ -39.5 dBu input	< 0.007%
Input to Input Crosstalk @1 kHz	
@ +21 dBu sensitivity	110 dB Typical, 90 dB Max
@ +10 dBu sensitivity	105 dB Typical, 90 dB Max
@ -10 dBu sensitivity	100 dB Typical, 90 dB Max
@ -39 dBu sensitivity	75 dB Typical
Input Dynamic Range	
@ +21 dBu Sensitivity	> 109.5 dB
@ +10 dBu Sensitivity	> 106.4 dB
@ -10 dBu Sensitivity	> 104.6 dB
Input Common Mode Noise Rejection	
@ +21 dBu Sensitivity	< 51, 20 Hz – 3 kHz < 43, 20 Hz – 10 kHz < 36, 20 Hz – 20 kHz
@ +10 dBu Sensitivity	< 57, 20 Hz – 3 kHz < 47, 20 Hz – 10 kHz < 41, 20 Hz – 20 kHz
@ -10 dBu Sensitivity	< 67, 20 Hz – 3 kHz < 58, 20 Hz – 10 kHz < 53, 20 Hz - 20 kHz
@ -39 dBu Sensitivity	< 60, 20 Hz – 3 kHz < 54, 20 Hz – 10 kHz < 50, 20 Hz – 20 kHz
Input Impedance (balanced)	7.2k Ω Nominal
Input Sensitivity Range (1 dB Steps)	-39 dBu min to +21 dBu max
Output Frequency Response	
20 Hz to 20 kHz @ all settings	+0.2/-0.5 dB
Output THD	0.005% Typical, +21 dBu Max Output Level
EIN (no weighting, 20 Hz to 20 kHz)	< -121 dB
Output Crosstalk @ 1 kHz	> 100 dB Typical, 90 dB max
Output Dynamic Range	> 108 dB
Output Impedance (balanced)	332 Ω
Output Level Range (1 dB Steps)	-39 dBu min to +21 dBu max
Q-LAN Channels	128
AEC Channels	
Q-SYS Core 110f	16
Q-SYS Core 110c	4
Core-to-Core Streaming Channels	128
MTP	Default = 16, With optional MD-110 SSD and MTP-32 = 32
USB B (Audio)	
Bit Depth	Selectable 16-bit, 24-bit
Number of Channels	up to 16x16
Sample Rate	48 kHz

Q-SYS Core 110 Series Specifications

Specification		Value		
Phantom Power		+48VDC, 10mA per input max		
Sampling Rate		48 kHz		
Power Consumption		60 watts, typical. 120 watts max		
A/D – D/A Converters		24-bit		
BTU / Heat load		205 BTU/Hour		
Device Dimensions (HxWxD)		1.7" (44 mm) x 18.9" (481 mm) x 11.3" (288 mm) Note: Depth without AC connector is 11.1" (284 mm)		
Shipping Dimensions (HxWxD)		6" (152mm) x 23" (584mm) x 14" (356mm)		
Device Weight		10.8 lb (4.9kg)		
Shipping Weight		11.5 lb (5.2 kg)		
Compliance	FCC Part 68 / TIA-968-B (USA)	ES203 021, CE, RoHS (Europe)	PTC200 (New Zealand)	NOM-151-SCTI (Mexico)
	JATE (Japan)	UL and C-UL listed (USA & Canada)	AC (Eurasian Customs Union)	PSTN01 (Taiwan)
	Industry Canada CS-03 (Canada)	AS/ACIF S002 and RCM (Australia)	ANATEL Resolution 473 (Brazil)	



Mailing Address:

QSC, LLC

1675 MacArthur Boulevard

Costa Mesa, CA 92626-1468 U.S.

Main Number: +1.714.754.6175

World Wide Web: www.qsc.com

Sales & Marketing:

Voice: +1.714.957.7100 or toll free (U.S. only) 800.854.4079

FAX: +1.714.754.6174

E-mail: info@qsc.com

Q-SYS™ Customer Support

Application Engineering and Technical Services

Monday - Friday 7 AM to 5 PM PST (Excludes Holidays)

Tel. 1.800.772.2834 (U.S. only)

Tel. +1.714.957.7150

Q-SYS 24/7 Emergency Support*

Tel: +1.888.252.4836 (U.S./Canada)

Tel: +1.949.791.7722 (non-U.S.)

*Q-SYS 24/7 Support is for Emergency assistance with Q-SYS systems only. 24/7 support guarantees a call back within 30 min after a message is left. Please include, Name, Company, Call Back Number and description of the Q-SYS emergency for prompt call back. If calling during business hours please use the standard support numbers above.

Q-SYS Support Email

qsyssupport@qsc.com

(Immediate email response times not guaranteed)

QSC

Technical Services

1675 MacArthur Blvd.

Costa Mesa, CA 92626 U.S.

Tel: 1.800.772.2834 (U.S. only)

Tel: +1.714.957.7150

FAX: +1.714.754.6173

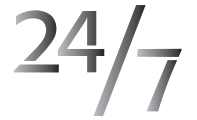

Q-SYS™ Customer Support