



DSP 306

Digital Audio Processor



User manual

MENU

Chapter 1 Introduction	- 1 -
Chapter 2 Technical parameters	- 2 -
Chapter 3 Functions structure and panel operation	- 3 -
Chapter 4 Operation of control software - Mconsole	- 7 -
4.1 Operating condition	- 7 -
4.2 Connections setting	- 8 -
4.3 DSP functions setting	- 10 -
4.3.1 DSP functions setting - INPUT	- 11
-	
4.3.2 DSP functions setting - NOISE GATE	- 11 -
4.3.3 DSP functions setting - PEQ-X (input and output)	- 12
-	
4.3.4 DSP functions setting - DYNAMIC EQ	- 14
-	
4.3.5 DSP functions setting - DELAY (input and output)	- 14 -
4.3.6 DSP functions setting - MATRIX MIX	- 15
-	
4.3.7 DSP functions setting - COMPRESSOR	- 15
-	
4.3.8 DSP functions setting - LIMITER	- 16
-	
4.3.9 DSP functions setting - OUTPUT	- 16
-	
4.4 Monitoring and setting of channels	- 16
4.5 -	
Menu - File	- 18
4.6 -	
Menu - Device (including Device lock)	- 19
4.7 -	
Menu - Connection	- 22
4.8 -	
Menu - Preset	- 23
4.9 Menu - System	- 23 -
-	
4.10 FIR filter and function	- 24
-	
4.10.1 FIR filter and applications	- 24
-	
4.10.2 Using third party software to set FIR magnitude and phase	- 26

Chapter 1 Introduction

DAP0306F\DAP0408F is a 3in6out\4in8out FIR DSP speaker processor, integrated with high performance DSP process, Dynamic EQ, FIR filter and other powerful function. User can take an easy way to set their speakers parameters.

With RJ45\USB and common series connectors, PC software Mconsole provides user a easy way to control multiple devices. RS232 connectors support device being controlled from third-party system.

Applications

Meeting room
Broadcast
Multi-function hall

Features

- 1 4 analog inputs and 8 analog outputs.
- 2 High performance DSP process, 96k24bit sampling rate.
- 3 Input with 15 bands PEQ, output with 10 bands PEQ.
- 4 Support HPF and LPF with Butterworth\Bessel\Linkwitz-Riley. Support LSLV and HSLV, ALL-PASS filters.
- 5 Input with 3 bands Dynamic EQ.
- 6 Input with 4 x 1024Taps 48k FIR linear phase setting.
- 7 Output with 4 x 512Taps 48k FIR linear phase setting.
- 8 Support presets archiving and locking, hide setting parameters.
- 9 Control connections: USB or TCP/IP. Configured with RS232 central control connection.
- 10 Nice GUI windows7/8/10/11 software

Chapter 2 Technical parameters

DAP0306F/DAP0408F	
1. DSP Process	
Process:	ADI SHARC 21489 450MHz
System delay:	1.8ms
AD/DA:	24-bit 96KHz
2. Analog Audio Inputs and Outputs	
Input:	3 or 4 channels balanced.
Input interface:	XLR(Neutrik®)
Input impedance:	20KΩ
Max input level:	16dBu/Line
Output:	6 or 8 channels balanced. Line level
Output interface:	XLR(Neutrik®)
Output impedance:	150Ω
3. Audio Performance Specifications	
Frequency response:	20Hz-20kHz(+0.5dB)/Line
THD+N:	-90dB(@0dBu,1kHz,A-wt)/Line
Ground noise:	20Hz-20kHz, A-wt, -93dBu
SNR:	108dB(@16dBu,1kHz,A-wt)/Line
4. Connect Ports and Indicators	
USB:	Type A-B, free driver
RS232:	Serial port communication
TCP/IP interface:	RJ-45
Indicator light:	Clip, level, edit, mute
5. Electrical and Physical	
Supply:	AC100V ~ 240V 50/60 Hz
Products Dimensions	483mmx215mmx44.5mm
Packaged Dimensions	537mmx343mmx77mm
Net Weight	3.6kg
Packaged Weight	4.0kg
Operating temperature:	-20°C ~ 80°C

Chapter 3 Functions structure and panel operation

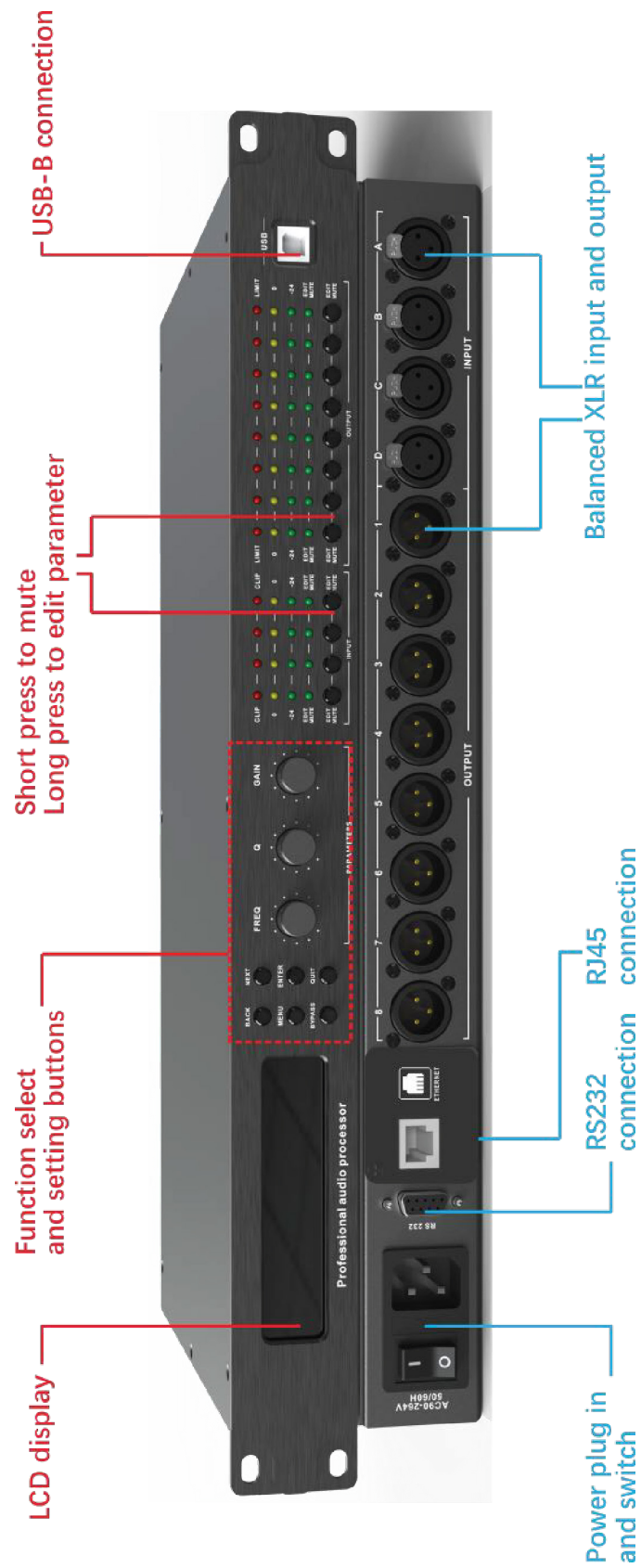

Dimension (mm)

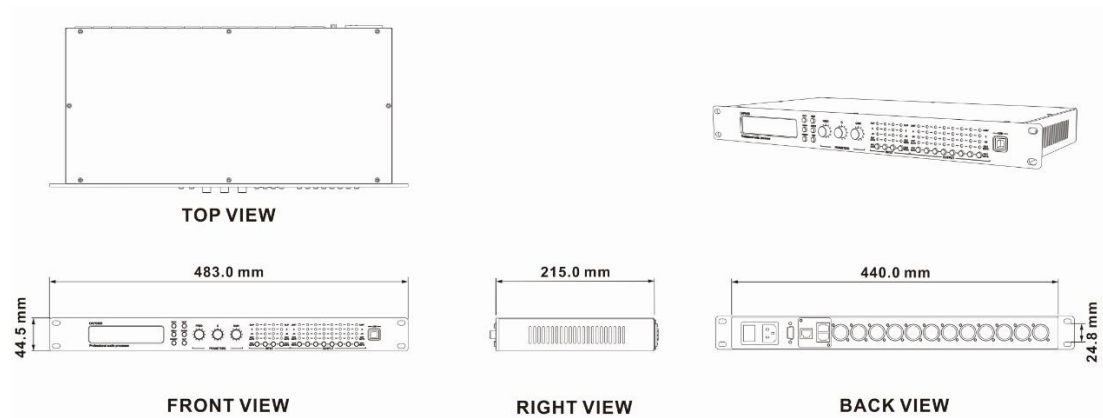

Operating front panel



① Press **MENU**, it will show menu list, using **NEXT** or **BACK** to select functions: GLOBAL MEMORY, INPUT SECTION, MATRIX, SYSTEM, press **QUIT** to exit.

Functions in panel	Menu list	Remark
1.GLOBAL MEMORY	RECALL a Memory STORY a Memory DELETE a Memory	
2.INPUT SECTION	A ANALOG B ANALOG C ANALOG D ANALOG	
3.MATRIX	Routing Out.1=Input A*....	Long press such output channel button under LED to change.

② Press **BYPASS** it will quickly show RECALL a Memory function, using **EXT** or **ACK** select presets and then press **TER** enable one of presets.

Operation of buttons on front panel - Input & Output Channels

① When user need to quickly mute input or output channel, shortly press button under the LED of such channel, the light will turn red.



② When user need to set parameter of input or output channel, long press button under the LED of such channel, the light will turn blue.



Functions - Input channels	Buttons for setting	Buttons for setting
IPX Input X Gain		
IPX Input X Polar	+,-	
IPX Input X PEQ:1...15	FREQ, Q, GAIN	BYPASS
IPX Input X HPF	FREQ, Q	BYPASS
IPX Input X LPF	FREQ, Q	BYPASS
IPX Input X Delay	GAIN	
IPX Input X Noise Gate	FREQ	BYPASS
IPX Input X Noise Gate	Q, GAIN	BYPASS
IPX Input X DEQ:1...3	FREQ, GAIN	BYPASS
IPX Input X DEQ:1...3	Q, GAIN	BYPASS
IPX Input X DEQ:1...3	Q, GAIN	BYPASS
IPX Input X DEQ:1...3	Q, GAIN	BYPASS
IPX Input X Fir		BYPASS

Functions - Output channels	Buttons for setting	Buttons for setting
OPX Output X Gain		
OPX Output X Polar	+,-	
OPX Output X PEQ:1...15	FREQ, Q, GAIN	BYPASS
OPX Output X HPF	FREQ, Q	BYPASS
OPX Output X LPF	FREQ, Q	BYPASS
OPX Output X Delay	GAIN	
OPX Output X Compress	FREQ, Q, GAIN	BYPASS

Functions - Output channels	Buttons for setting	Buttons for setting
OPX Output X Compress	Q, GAIN	BYPASS
OPX Output X Limiter	Q, GAIN	BYPASS
OPX Output X Limiter	GAIN	BYPASS

Remark: **X** means the No. of such channel user has selected. If find no effect after setting parameter, please check whether select **BYPASS** or not.

③ When user need to link channels and then set their parameter, long press button under the LED of each channel, the light will turn blue. LCD will display "IPX+" or "OPX+", means the second channel or other channels will be set same with first channel.

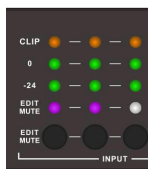

When user need to quickly mute channels in link setting, shortly press button under the LED of one of channels, all the lights will turn pink.

Chapter 4 Operation of control software - Mconsole

Mconsole provides user with a fast interaction to control one or more devices through multiple methods: TCP/IP, USB, common serial port (RS232). Easily set DSP functions of device, and check central control codes. The configuration parameter can be stored in presets, convenient for various applications.

4.1 Operating condition

Mconsole is suitable for Win7/8/10/11 x86/x64 PC system with Microsoft .NET Framework 4.0. When connecting device in USB method, the device will automatically ejects the storage disk, user can unzip software in Windows, no need to setup.

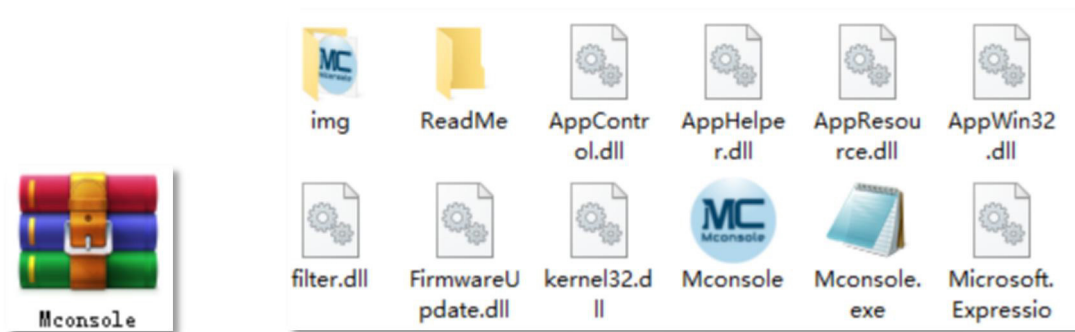

Double click **Mconsole.exe**, the main interface will pop up.

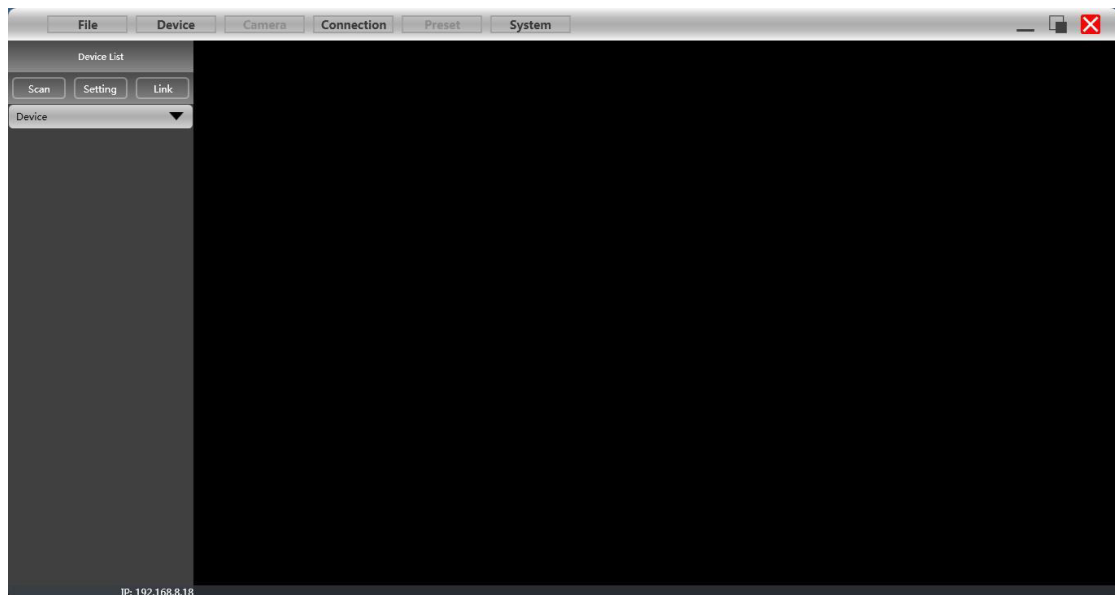

4.2 Connections setting

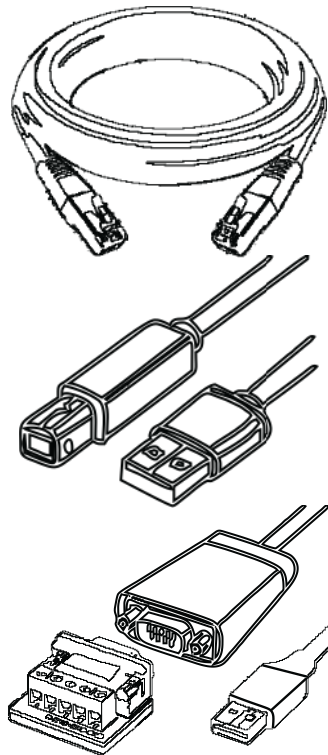

If connect device by using network cable, click **Setting** in Device List, choose **TCP** in Connection windows.



If connect device by using USB A-B, click **Setting** in Device List, choose **USB** in Connection windows.

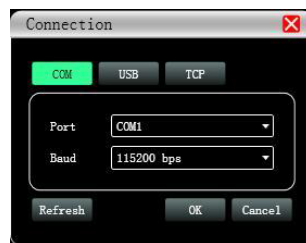

If connect device by using network cable, click **Setting** in Device List, choose **COM** in Connection windows. Please check port and baud rate carefully for 232 before setting.

The software will scan device the method set in last time, to check if device is connected. If successfully connected, devices will be shown in device list.

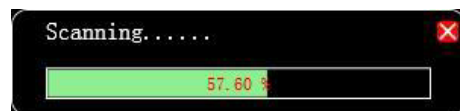

User can mute device, refresh connecting, or delete device in this window. Single click device, to load function interface.

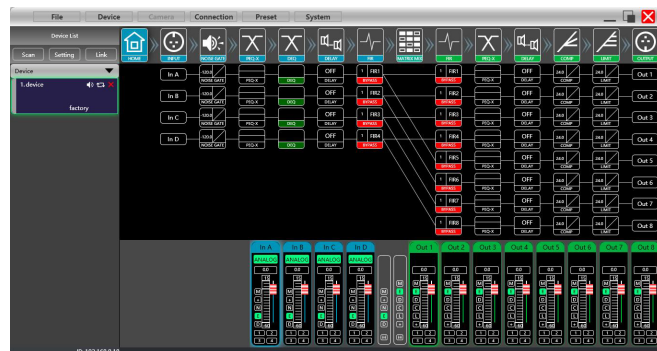

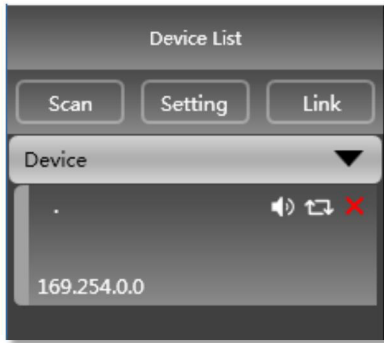

When using TCP control, there is a situation that only one point is displayed after scanning, but can not connect device. In this case, user need to change the IP address of the device to the same network segment as the PC computer.



Right-click the device enclosure, a Net Setting window will show.

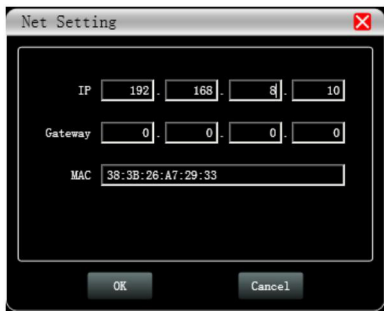

Set IP address of device refer to IP showed in the bottom of the software. Set the first three

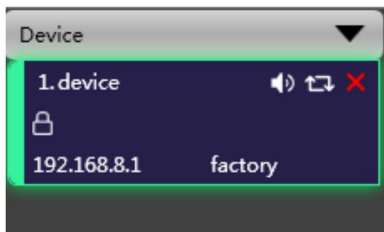
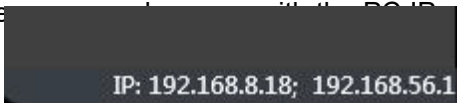

Successfully scanned and connected.

User can link multiple same devices in group by clicking Link button, and then set group device, group name and main device, link mode and parameter according to needs.

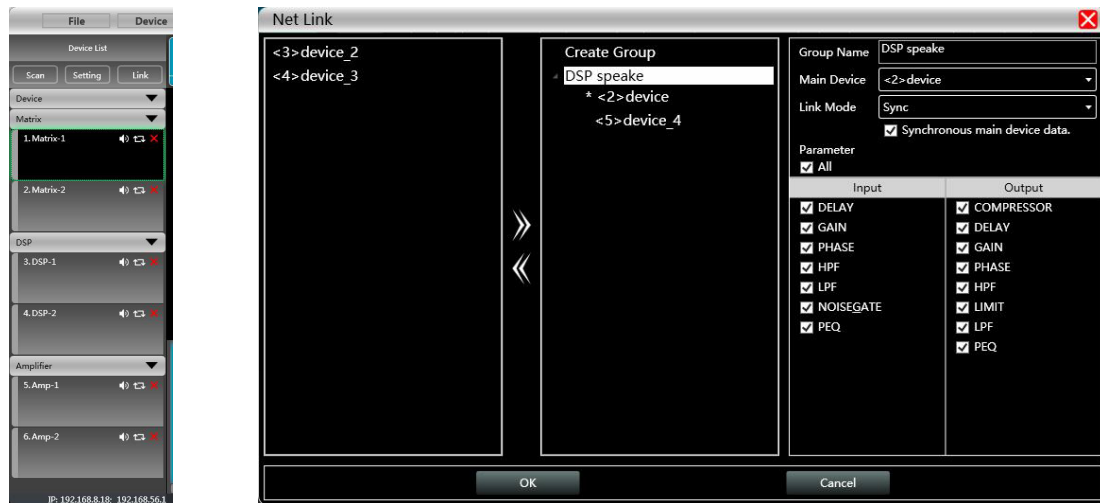

4.3 DSP functions setting



Double-click HOME icon to open all functional interfaces, or double-click a function icon separately to open the corresponding interface. When multiple function windows opened, users can drag the window to switch function Settings.

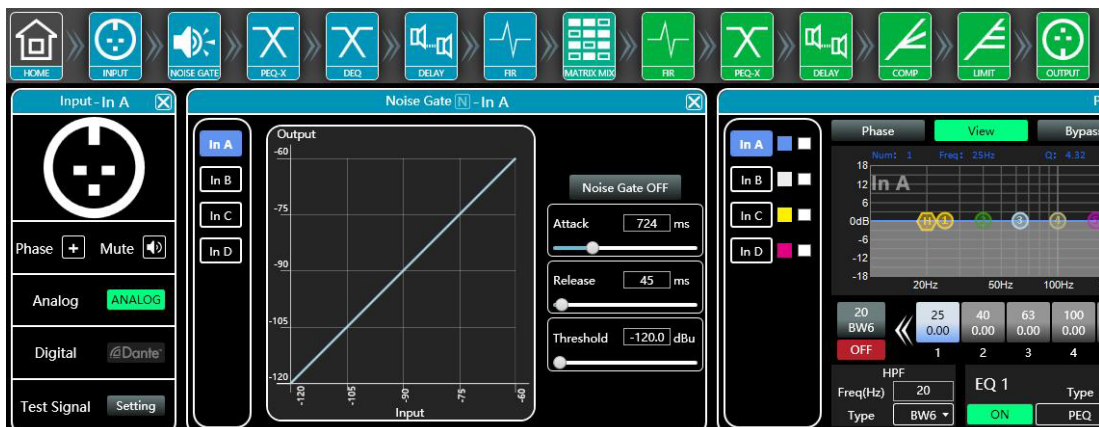

4.3.1 DSP functions setting - INPUT



- Set Phase of input;
- Set Mute of input;
- In Pro version, user can select Analog\AES\Dante input signal;
- When choosing test signal, user can select Sine/Pink Noise/White Noise for each input channel.

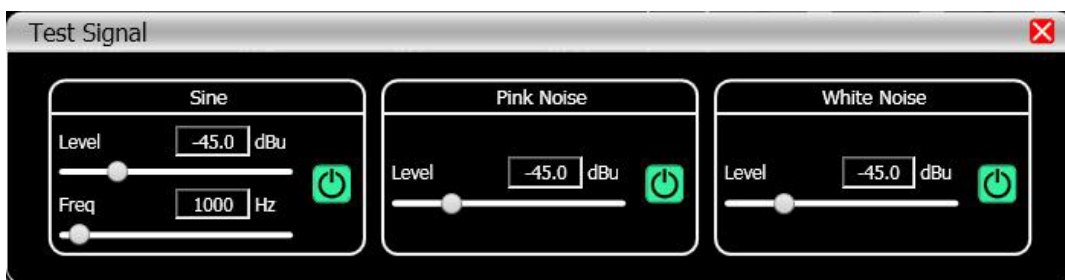

4.3.2 DSP functions setting - NOISE GATE

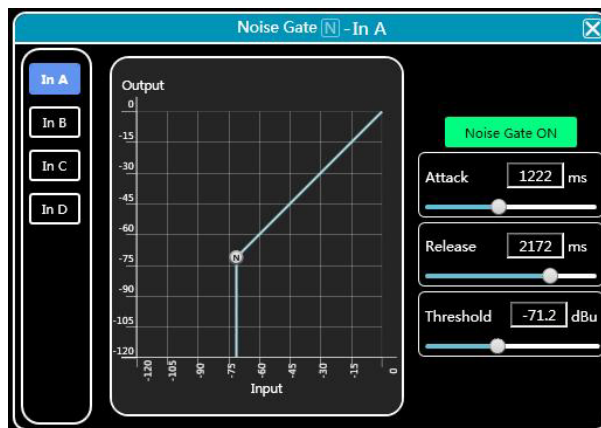

- Attack: 1 to 2895ms;
- Release: 1 to 2895ms;
- Threshold: -120 to -60dBu;
- Click to enable this function.

4.3.3 DSP functions setting - PEQ-X (input and output)

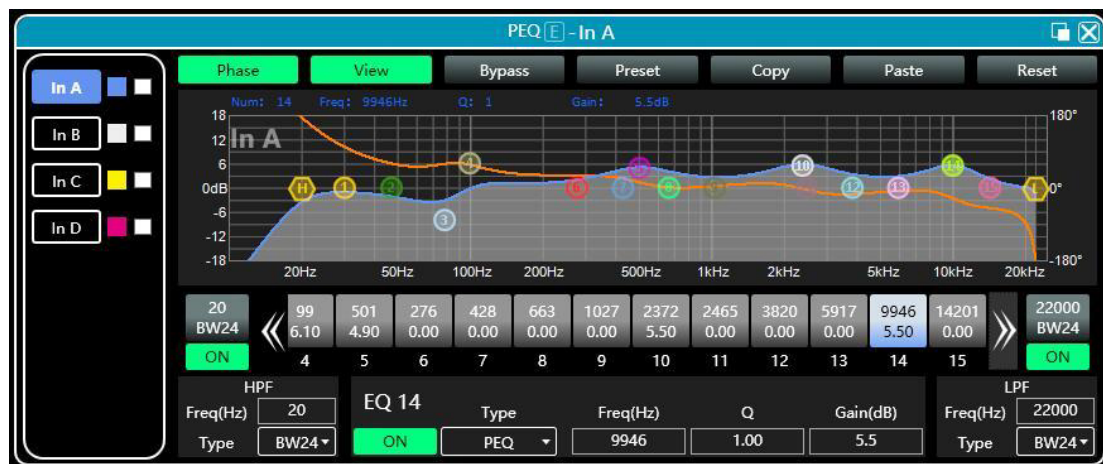

High pass filter



enter value of frequency and select type, press to enable this function:
Butterworth 6/12/18/24/36/48, Bessel 12/24/36/48, Linkwitz-Riley 12/24/36/48.

Low pass filter



enter value of frequency and select type, press to enable this function:
Butterworth 6/12/18/24/36/48, Bessel 12/24/36/48, Linkwitz-Riley 12/24/36/48.

PEQ 15 bands for input channel

Type: PEQ/LSLV/HSLV/ALLPASS-1/ALLPASS-2;
Freq(Hz) Q Gain(dB): input value or use mouse pulley to set value;
Users can also drag the frequency dot on the curve to adjust.

PEQ 10 bands for output channel

Type: PEQ/LSLV/HSLV/ALLPASS-1/ALLPASS-2;
Freq(Hz) Q Gain(dB): input value or use mouse pulley to set value;
Users can also drag the frequency dot on the curve to adjust.



Phase curve: display the phase curve of the current channel.

View: show or hide all balance control points.

Bypass: turn on or off all equalizer EQ of the current channel at the same time

Preset: save all the setting parameter of the equalizer of the current channel to the computer, and recall the channel equalizer parameter of the computer, which can be called across channels and devices.

Copy: copy the current channel equalizer parameter value, which can be pasted to other similar channels (such as input channel parameter can only be copied to other input channels).

Paste: used in combination with the copy button to paste the last copied equalizer parameter value to the current channel.

Reset: reset the equalizer parameter to the default parameter values.

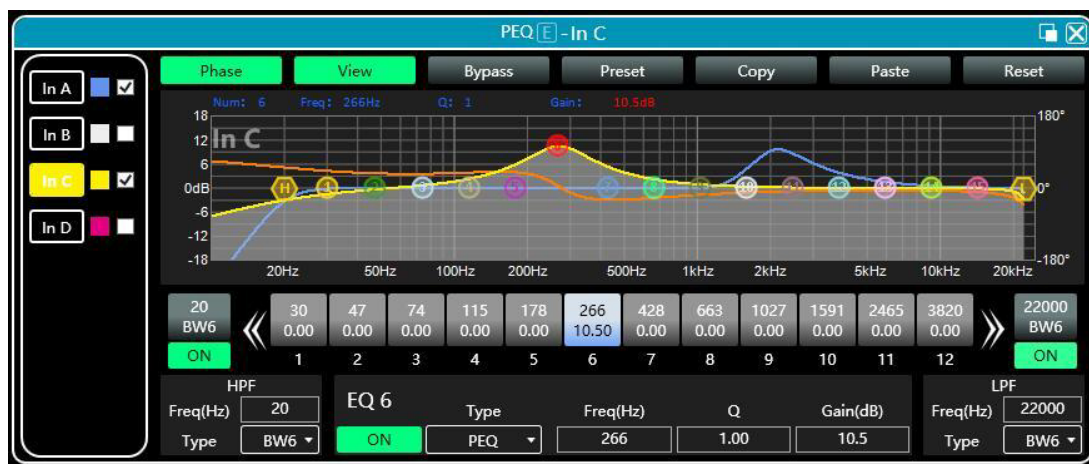

As shown in the figure above, the left side **IN 1** is the switching button for each channel. Click to switch the EQ channel, and the color is the currently selected channel. **IN 1** is the curve color of the EQ channel. For each channel's EQ **IN 1** display switch, check it to enable it to display the curves of other channels in the current channel interface.

4.3.4 DSP functions setting - DYNAMIC EQ

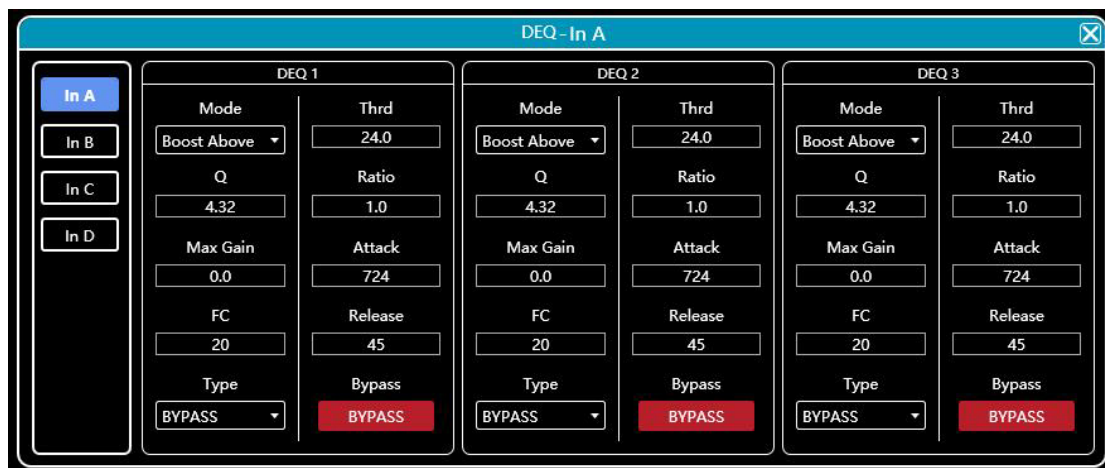

- Mode: Boost Above\Boost Below\Cut Above\Cut Below
- Threshold: -90 to 24.0dBu
- Q: 0.27 to 15
- Ratio: 1.0 to 100.0
- Max Gain: 0.0 to 12.0
- Attack: 1 to 2895ms
- Frequency: 20 to 22000Hz
- Release: 1 to 2895ms
- Type: BYPASS\PEQ

4.3.5 DSP functions setting - DELAY (input and output)

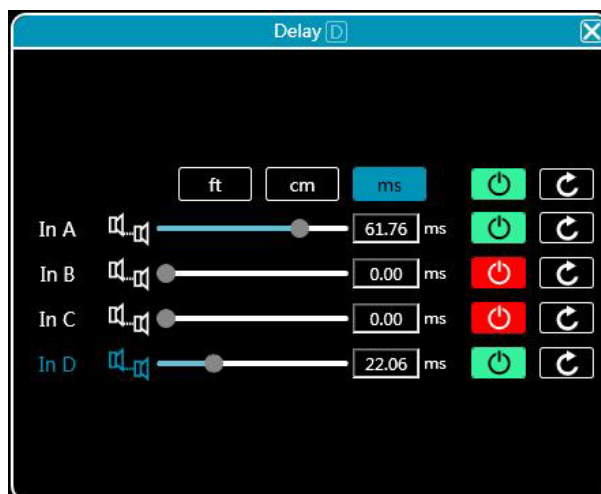

- Max 1000ms for input channel;
- Max 1000ms for output channel;
- Click to **enable** this function;
- Click to **reset** each channel;
- User can **switch** ft/cm/ms measurement for delay.

4.3.6 DSP functions setting - MATRIX MIX

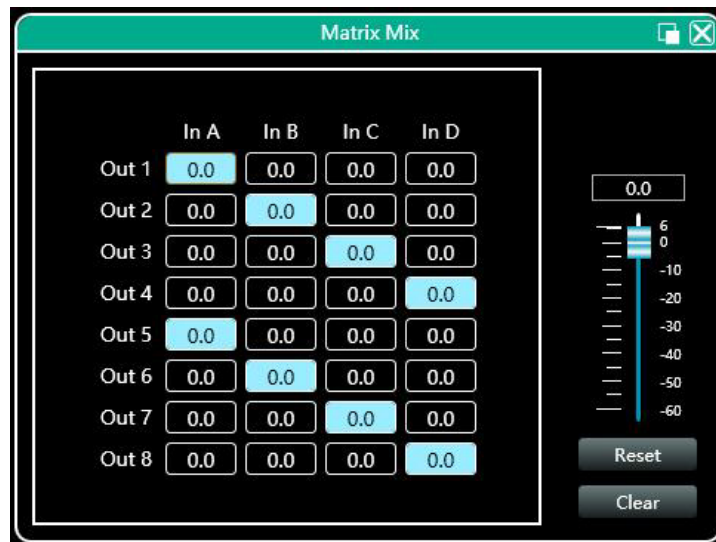

In the above figure, input channel (on top side) corresponds to output channel. The value box with a value is mixing key of channels. When the mixing key is green (double-click the value box to switch the state), the input channel and output channel signal realizes the mixing function.

The right part of the above figure contains the gain, reset button, and clear button of the matrix mix. Click the value box on the left, and then drag the sliding block of the matrix mix gain or enter a value in the value box to adjust the matrix block. Click the reset button to reset the matrix mixing function to the initial one-to-one state; click the clear button to clear all the matrix mixing functions, and there is no correspondence between the input and output of the device.

4.3.7 DSP functions setting - COMPRESSOR

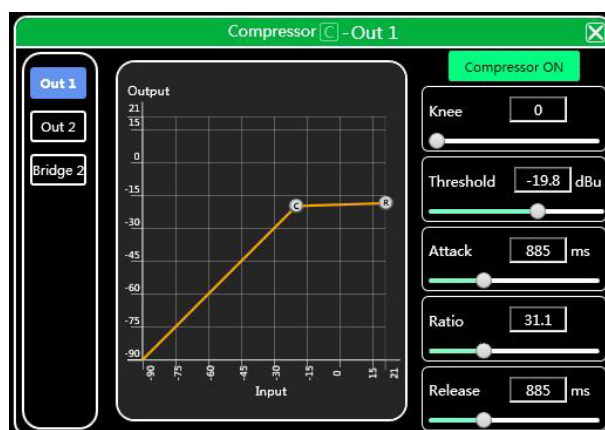

- Soft knee: 0 to 30;
- Threshold: -90.0 to 24.0 dB;
- Attack: 1 to 2895 ms;
- Ratio: 1.0 to 100.0;
- Release: 1 to 2895 ms;
- Click to **enable this function**;

4.3.8 DSP functions setting - LIMITER

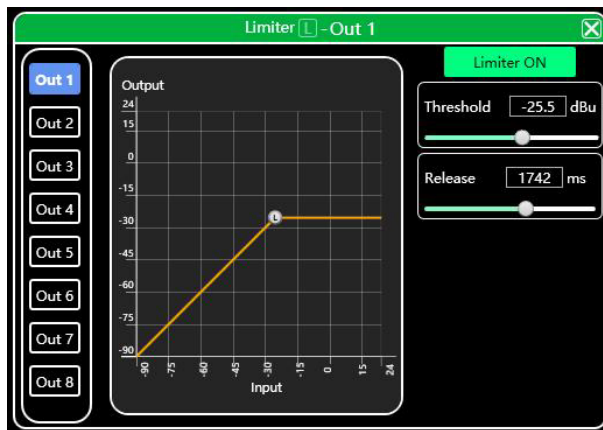

- Threshold: -90.0 to 24.0dBu;
- Release: 1 to 2895 ms;
- Click to **enable this function**;

4.3.9 DSP functions setting - OUTPUT

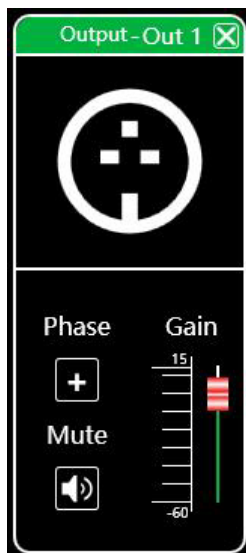

- Set phase of signal;
- Set mute of output channel;

4.4 Monitoring and setting of channels

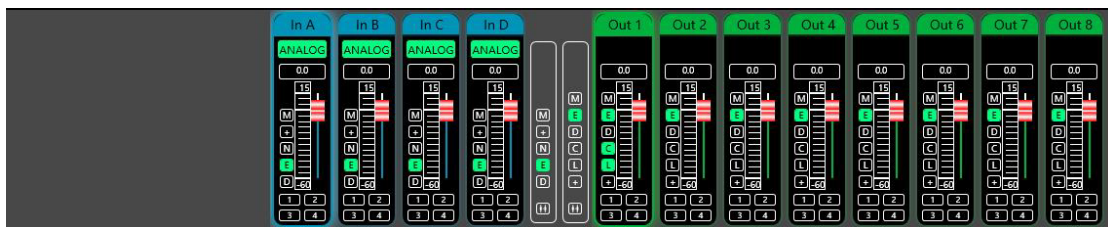

User can monitor gains level of input and output channels.

4.4.1 Channel gain level

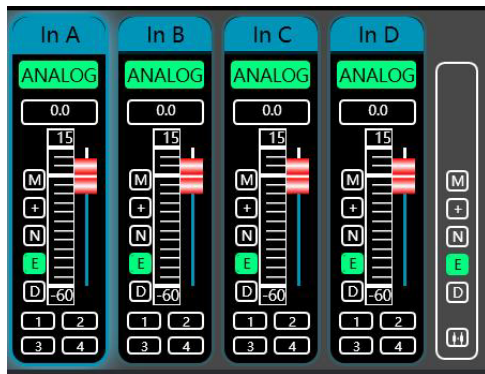

There are 2 kinds of input signal in device: ANALOG and testing signal. It will show a label for user.

Input value, drag gain fader or use mouse pulley to set value of gain.

4.4.2 Quick buttons of DSP in channels



M Mute
+ Phase N
Noise Gate E
PEQ D Delay

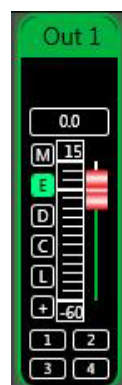

M Mute E PEQ
D Delay C
Compressor
L Limiter +
Phase

4.4.3 Group and channels link

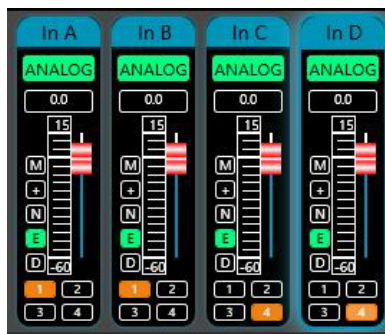

User can quickly set channels in groups for opening or closing mute, phase, noise gate, PEQ and delay function.



M Mute
+ Phase
N Noise Gate
E PEQ
D Delay

Channels link for input

M Mute
E PEQ
D Delay
C Compressor
L Limiter
+ Phase

Channels link for output

When click link button, Channels Link window would show as below:

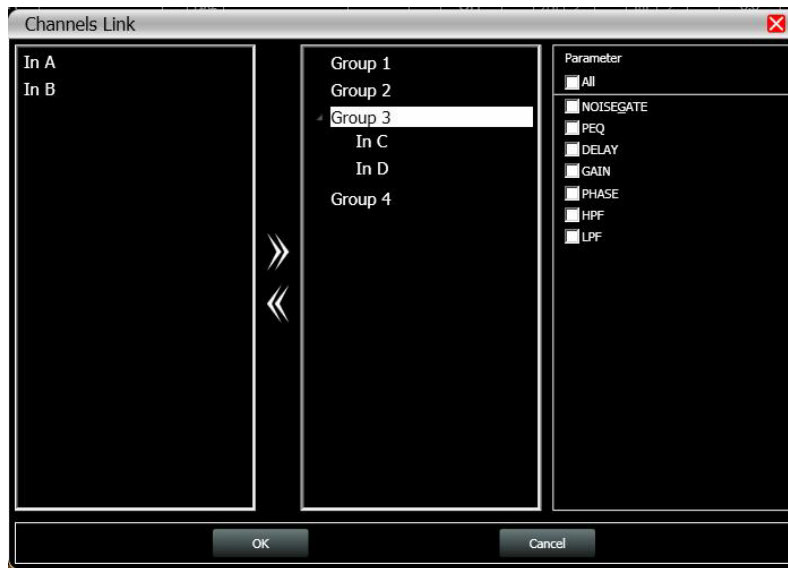

Select the corresponding channels to link, they will be in group for user to set parameter.

4.5 Menu - File

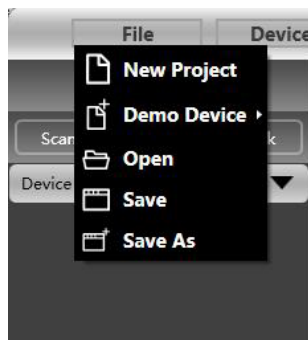

New project: the project is restored to the initial open state.

Demo Device: user can view all the functions of the device without affecting the specific device connected.

Open: open an existing device management project from the computer disk.

Save: save the current equipment management project in the computer disk.

Save as: save the current equipment management project to the computer disk.

4.6 Menu - Device (including Device lock)

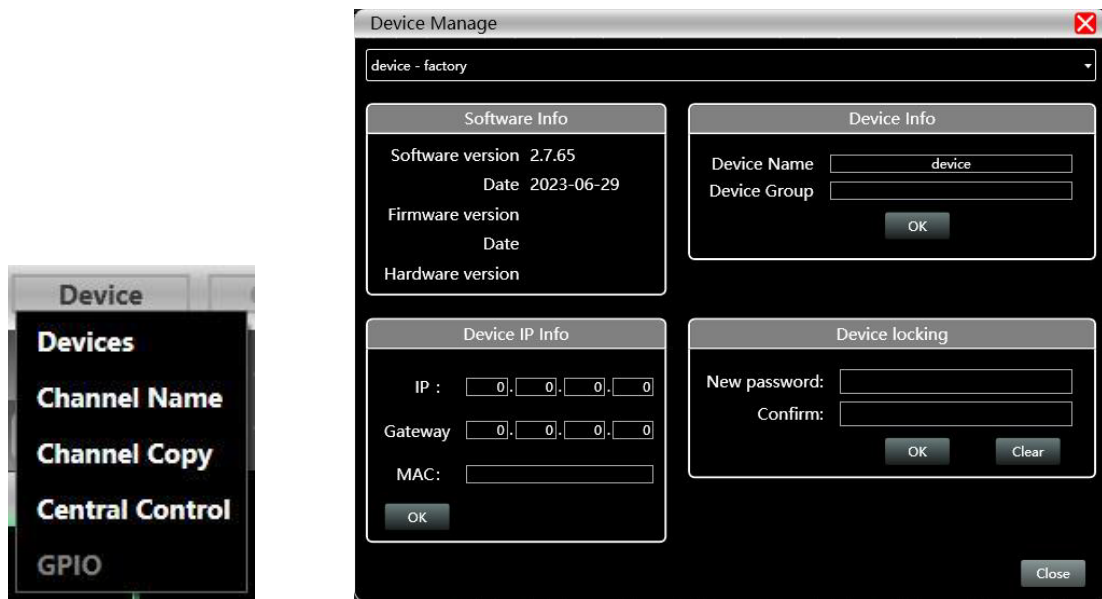

Devices: view or modify the software version information, device name and device IP address of the upper and lower computer of the device. Set password of device.

Channel name: set the name of each input and output channel, with memory function.

Channel copy: copy device input and output channel parameter, can realize cross-device copy parameter (Note: the same type of device is required).

Central control: provides user a quickly way to inquiry code of Center Control setting. More details, please refer to another user manual <Center Control Code User Manual>, it provides whole guide and codes for user to match every specific system.

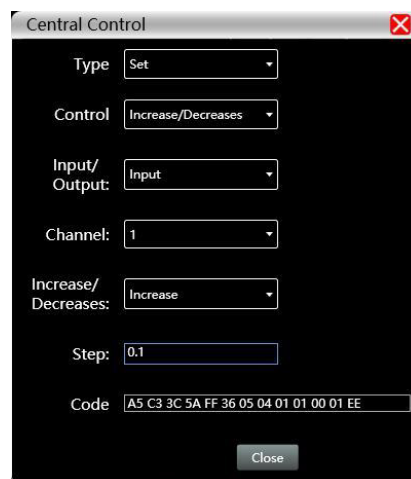

Device locking User can set his own password of this device to protect audio project after setting parameters. After unlock the device in software, user can clear password or reset the password.

The password can be in four-digit format (0,1,2...9), so that user can use the control software or the front panel of device to unlock the password. If the device is locked, there is a icon showed in software and LCD display, as per Figure 7.18.1

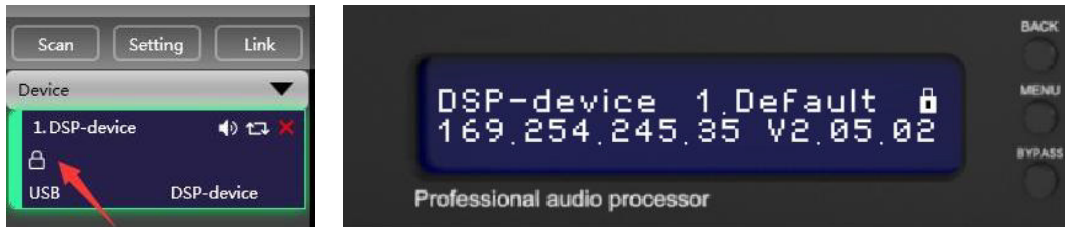
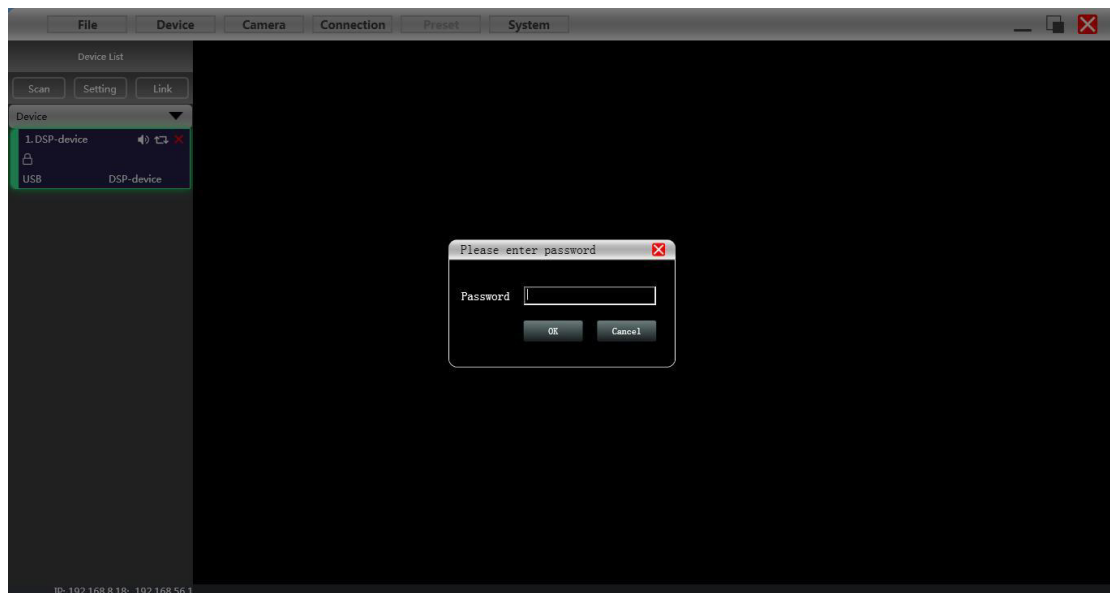
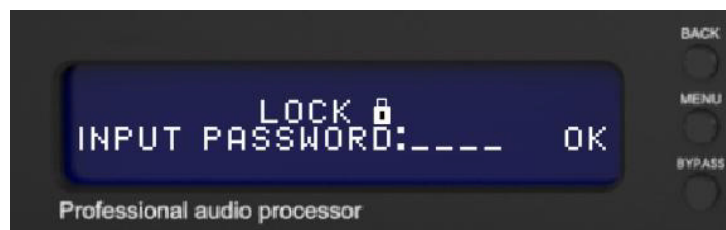

Figure 7.18.1



Input the password in software to unlock the device



Input the password in LCD display to unlock the device

When device is locking, user can press mute button of each channels in front panel. Press either of **BACK**, **NEXT**, **MENU**, **ENTER**, **BYPASS**, **QUIT** button, LCD will show interface to input password, press **GAIN** button to select digit, and press **BACK** or **NEXT** to select digit position. Then select "OK" and press **ENTER** to unlock device.

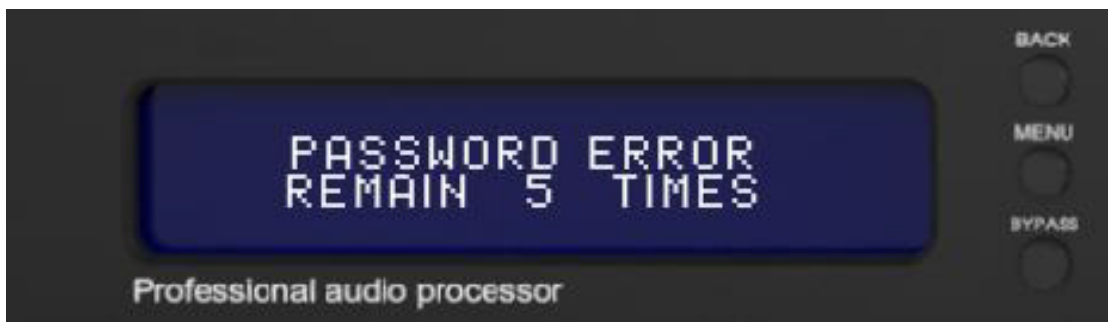
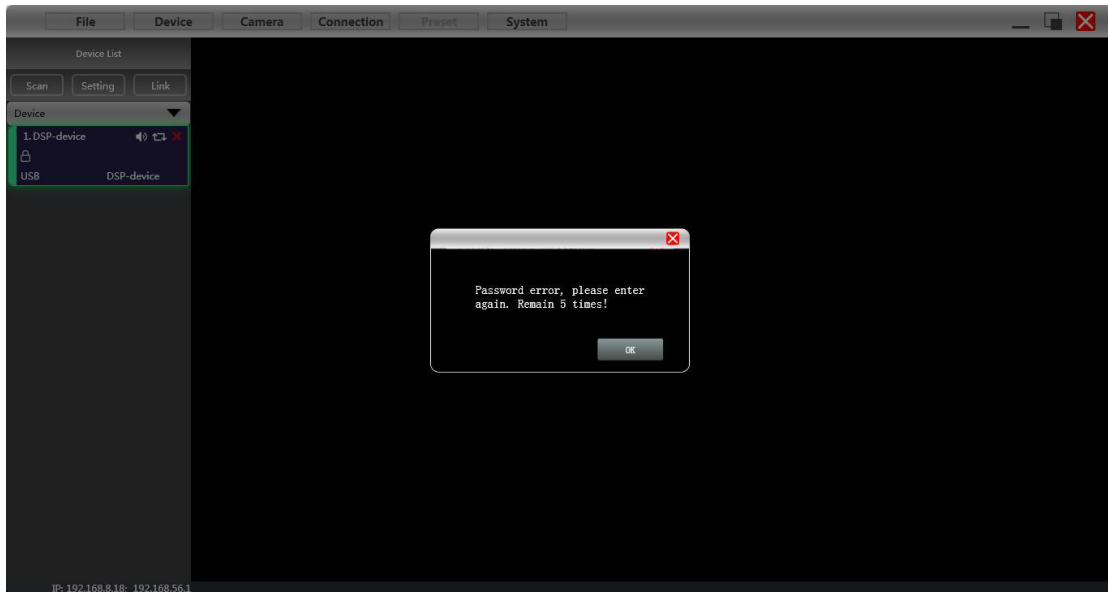

If wrong input, software will remind user there is only 5 times to input right password. More than 5 times, device can't be unlock any more, user have to return this device back to dealer or factory. **The dealer or factory will reset the device and clear all parameter settings.**



Successfully input password and enter main interface

4.7 Menu - Connection



Port: set the connection mode, port number and baud rate, confirm the connection mode and then select the corresponding port.

Connect: connect and download the device parameter.

Disconnect: disconnect the connected device.

Connect all: connect and download the device parameter of all devices in the device list.

Disconnect all: disconnect all connected devices in the device list.

4.8 Menu - Preset

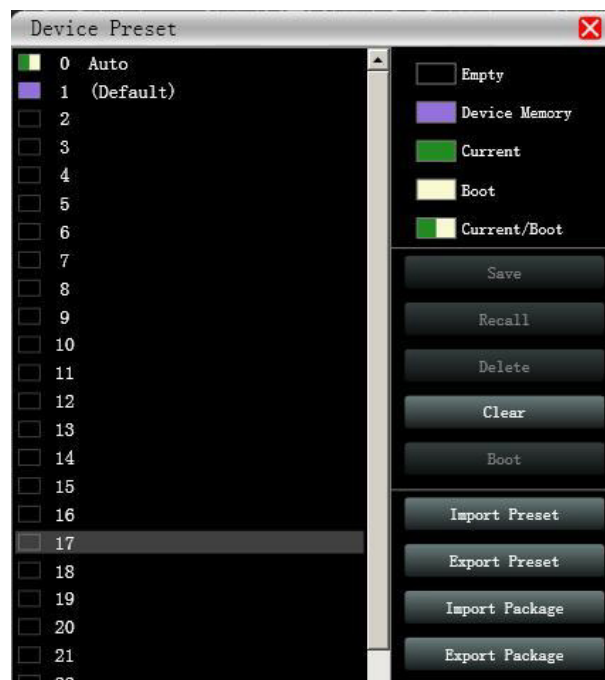

Save: select the saved gear, save all the parameter of the current automatic gear of the machine to the device preset (2~30 Preset bit).

Recall: call the device preset to the current automatic gear position.

Delete: delete the existing preset, the default file cannot be deleted, over written or saved.

Clear: delete all presets in the device.

Boot: select a certain preset, after setting it as the boot file, each time the device is powered on, it will automatically call the save the parameter; the last set parameter need to

be automatically saved, please set the automatic file to the boot file.

Import preset: import a single preset file on the computer.

Export the preset: export all the parameter of the current state to the computer, and generate a single preset file.

Import preset package: import the preset package file containing multiple presets on the computer.

Export preset package: pack multiple presets in the machine's preset into one preset package and export it to the computer.

4.9 Menu - System

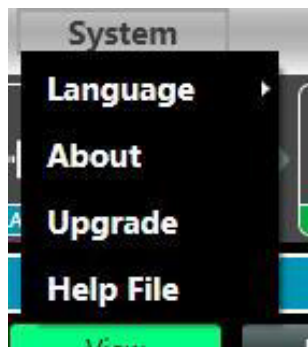

Language: multi-language switching, supports simplified, traditional, and ENGLISH.

About: current control software and device firmware version information.

Upgrade: use can upgrade the firmware by using this function, a upgrade *.bin* file should be needed from seller or speaker factory. In general, no need to upgrade the firmware in device. Only there is a bug or new function in software, upgrade function will be used.

4.10 FIR filter and function

4.10.1 FIR filter and applications

When user uses PEQ to adjust audio signal and set a linear magnitude, he can find the phase of signal changed, due to IIR filter. However, DSP products provide user a useful tool FIR filter to adjust audio signal with a linear phase.



Some calculation:

$$\text{Frequency resolution} = \text{Sampling/Taps}$$

$$\text{Available min. frequency} \approx \text{Frequency resolution} * 3$$

Means when use adjust audio signal with 48kHz, 1024 taps, FIR filters will take effect in frequency above 141Hz of audio signal. The taps value more high, the FIR filter curve more steep.

FIR filter processing audio signal will produce a certain delay:

$$\text{Delay} = (1/\text{Sampling Hz}) * \text{Taps}/2$$

Taps Sampling	48kHz	96kHz
256	2.67ms, LF 563Hz	1.33ms, LF 1125Hz
512	5.33ms, LF 279Hz	2.67ms, LF 558Hz
768	7.99ms, LF 188Hz	4.00ms, LF 375Hz
1024	10.67ms, LF 141Hz	5.33ms, LF 281Hz



Applications:

- Linear of the phase curve of the

speaker;

- Match the phase and magnitude of different speaker models within the same product line, as well as different speaker models in the installation project to make it easier to debug speaker groups and arrays;

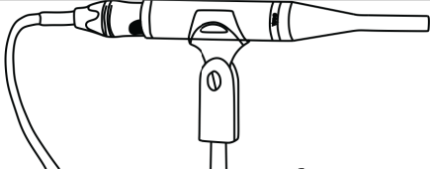
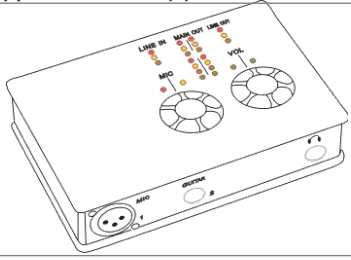
Devices required:

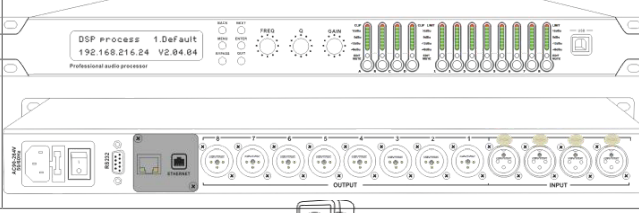
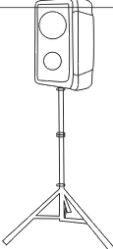
Measurement Microphone	×1	
Audio Interface	×1	
Windows PC (installed software including Smart, rePhase or FIR Designer, Mconsole)	×1	
FIR audio processor or DSP network power amplifier	×1	 

Connection schematic diagram:

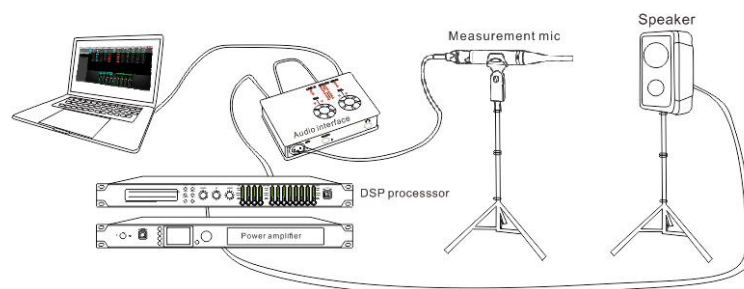

4.10.2 Using third party software to set FIR magnitude and phase

Step 1: measure phase curve of speaker in Smart V7



Step 2: copy curve to ASCII in Smart V7



Step 3: copy curve to software rePhase

“Import Measurement From Clipboard”

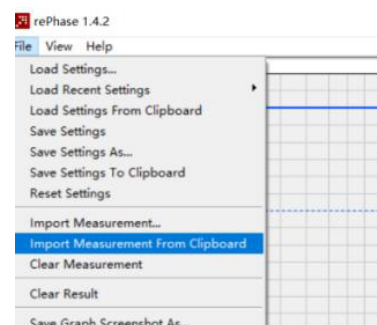

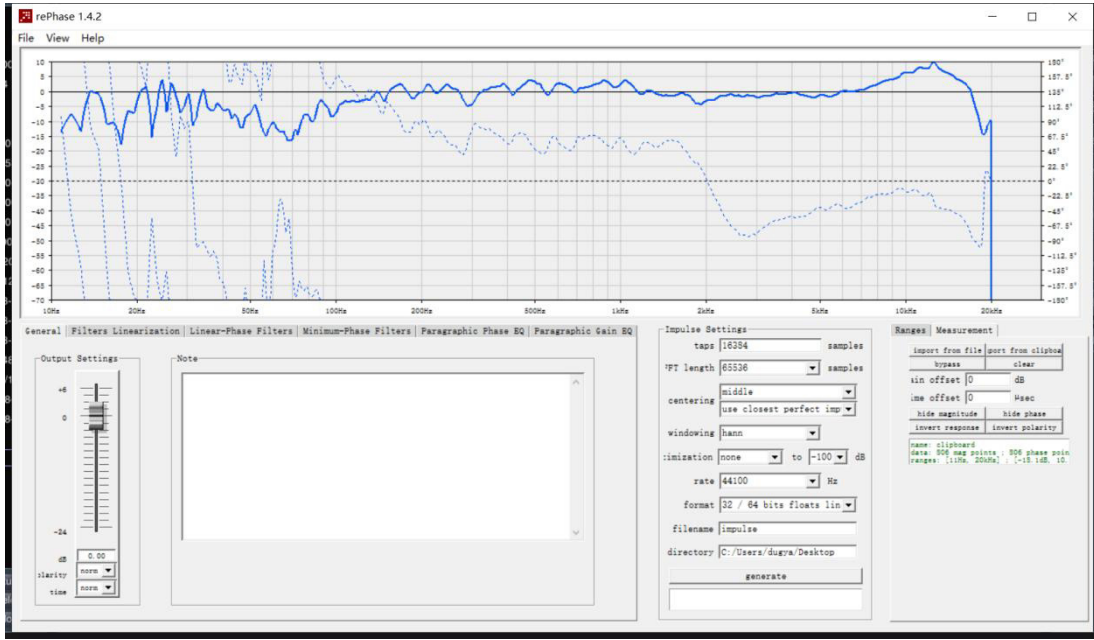

Step 4: adjust phase EQ or any other parameter in software, to match a linear phase for speaker

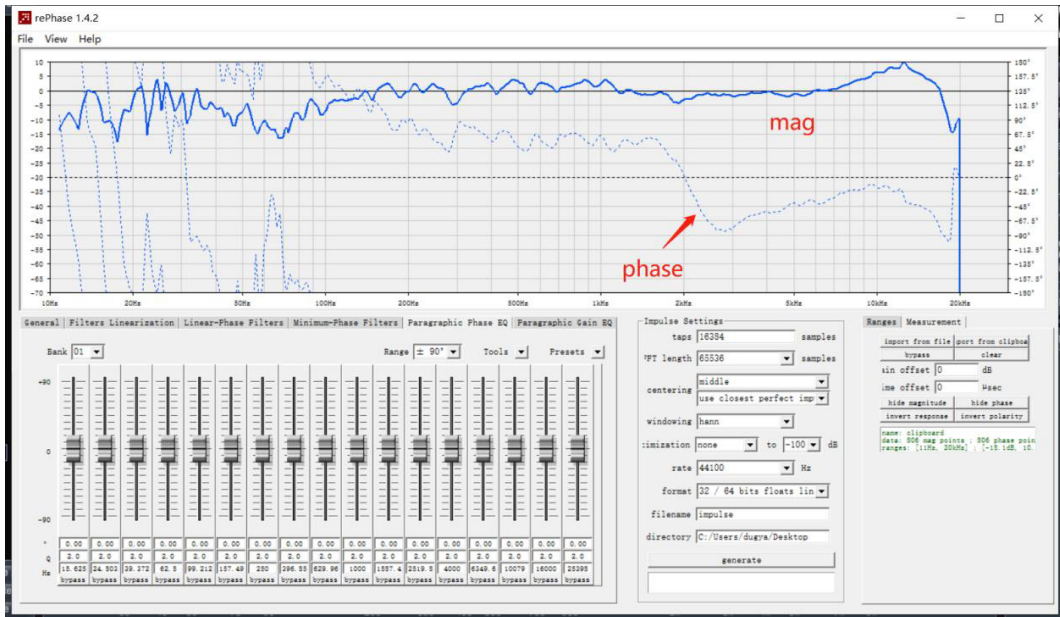

Step 6: import FIR .txt file in FIR audio processor or DSP network power amplifier

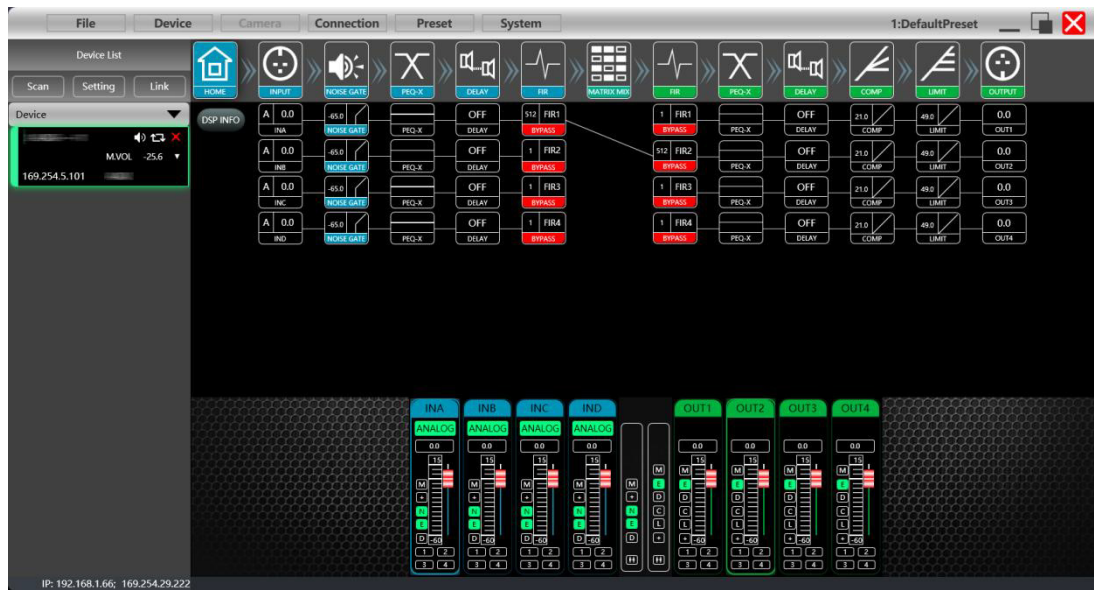

Open Mconsole software, user can choose an input channel or output channel as needed, such as FIR in output channel, it will show a FIR function window.

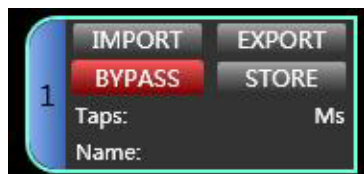
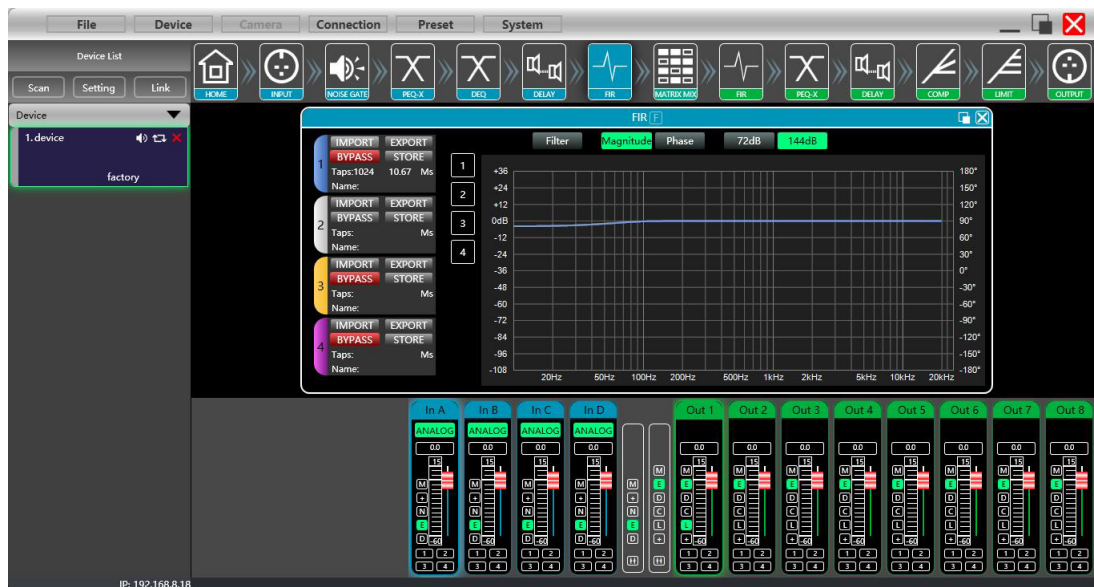

press **IMPORT** to import txt. file, than press **STORE** to effect this importing.



remember to cancel **BYPASS**.

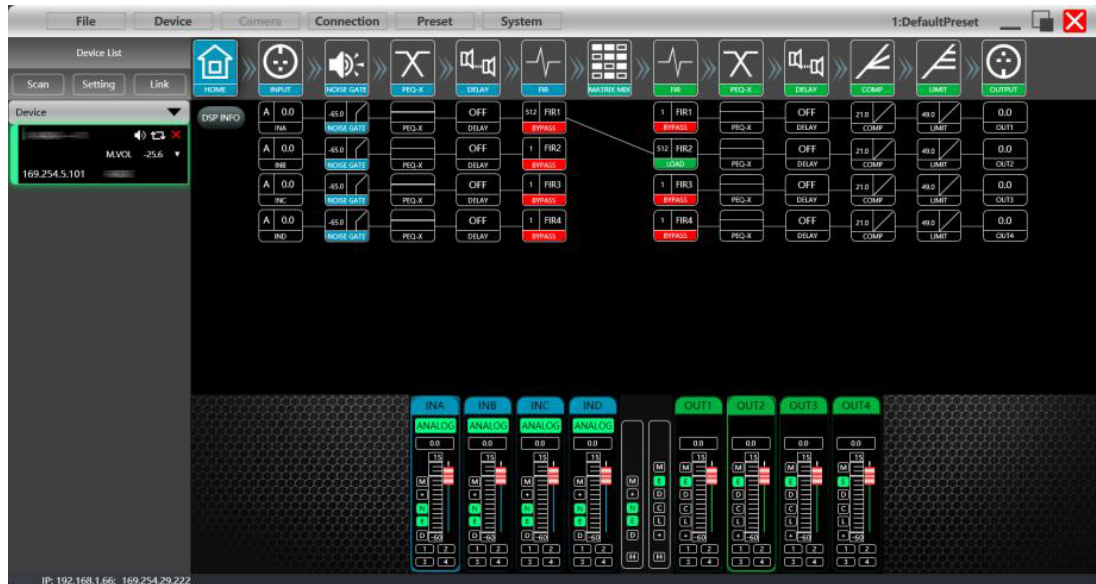

Step 8: measure the curve of speaker again, use can find it become more linear.



After all setting, please remember to save a preset for your hard working in the speaker.



IP: 192.168.1.66, 169.254.29.222

